

## INDEX

### INTRODUCTION

I - HEAD IDENTIFICATION	Pag.	5
II - TECHNICAL DATA OF CLASS	"	5
III - TECHNICAL DATA OF SUB-CLASSES	"	6

### INSTRUCTIONS

I - INSTALLATION AND SETTING UP	Pag.	11
a - Positioning of head	"	11
b - Transmission assembly	"	11
c - Lubrication	"	11
d - Assembling and Adjusting Sewing Parts	"	11
e - Adjusting and locking presserfoot arm	"	16
f - Setting front cover plate	"	16
g - Needle thread take-up adjustment	"	16
h - Electric lubrication control device	"	17
II - USE	"	19
a - Threading	"	19
b - Changing the needle	"	23
c - Setting the presserfoot	"	23
d - Setting of tensioning discs	"	23
e - Stitch length adjustment	"	23
f - Seam width adjustment	"	23
g - Problems due to improper handling of machine	"	24
III - MAINTENANCE	"	25
a - Every day	"	25
b - Every week	"	25
c - Every three months	"	25
d - Sharpening the knives	"	25

### SPARE PARTS CATALOGUE

I - HOW TO USE THIS CATALOGUE	"	29
a - Introduction	"	29
II - HOW TO ORDER	"	29
a - All parts	"	29
b - Needles	"	29
III - TABLES	"	31
IV - NUMERICAL INDEX OF PARTS	"	73

From the library of: Diamond Needle Corp

INSTRUCTIONS FOR

INSTALLATION AND TUNING

USE

MAINTENANCE

From the library of: Diamond Needle Corp

## I. INSTALLATION AND SETTING-UP

### a) Positioning of head

After motor is mounted on stand, proceed as follows:

1. Push the four shock absorbing rubbers onto the appropriate head mounting plate pins.
2. Place the machine head on the table and center the lower head holes onto the shock absorbing pins.

### b) Transmission assembly

1. Fit the transmission belt as in fig. 1.
2. Make sure that back of driving belt rides firmly and squarely on pump pulley.
3. Take-up belt play by adjusting motor clamp.
4. Level the machine head by adjusting the nuts of the bolts which fix the plate to the table.
5. Tighten up the lock nuts on these bolts.

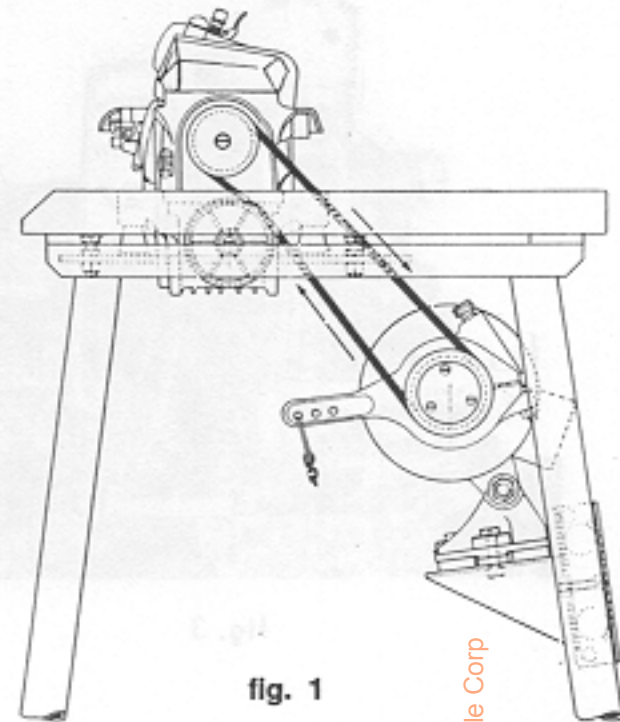

### c) Filling sump with lubricating oil

1. Unscrew cap A.
2. Pour in 1 3/4 pts. of VR. 604 oil (Esso Standard Teresso 43) (Bear in mind that the sump holds 2 pts.)
3. Check oil level. The oil visible through indicator glass G, should be between the two red lines.
4. Replace and tighten cap 'A'.
5. Put a few drops of oil on the needle clamp guide rod and upper looper bar before starting machine.
6. Run the machine free of work for about 5 minutes, progressively increasing the speed from 1500 r.p.m. to working speed.

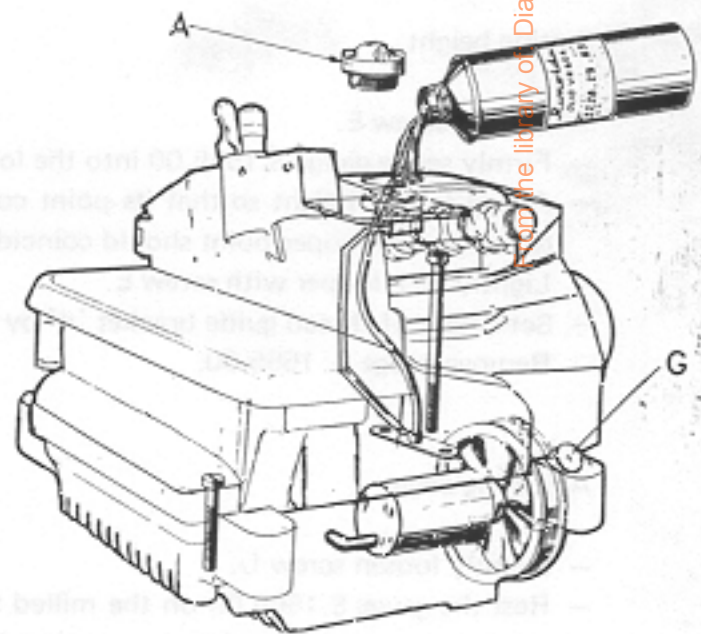

### d) Assembly and adjustment of sewing parts

Note: The following operations serve to adjust the timing of the machine.

1. Timing gauges required:
  - S. 1665.00 for all operations except No. 4 (fig. 4)
  - S. 1555.00 for operation No. 4 (fig. 4).
2. Preliminary stripping of:
  - Front cover plate
  - The two thread take-ups of the lower looper holder
  - Plate holding thread tensioners
  - Upper plate with oil spy-glass
  - Side plate protecting needle movement
  - Front feed dog.

### 3. Positioning the needle (fig. 3).

- With the needle plate properly mounted the needle should be centered for passage through the appropriate hole in the throat plate.
- With the needle at top dead centre the distance between the tip of the needle and the work plate, should be  $25/64''$
- For 228-00-04 and its derivatives, this distance should be  $3/8''$ .
- If adjustment of the needle clamp is necessary, loosen bolt A (fig. 3) and set distance with gauge S. 1665.00

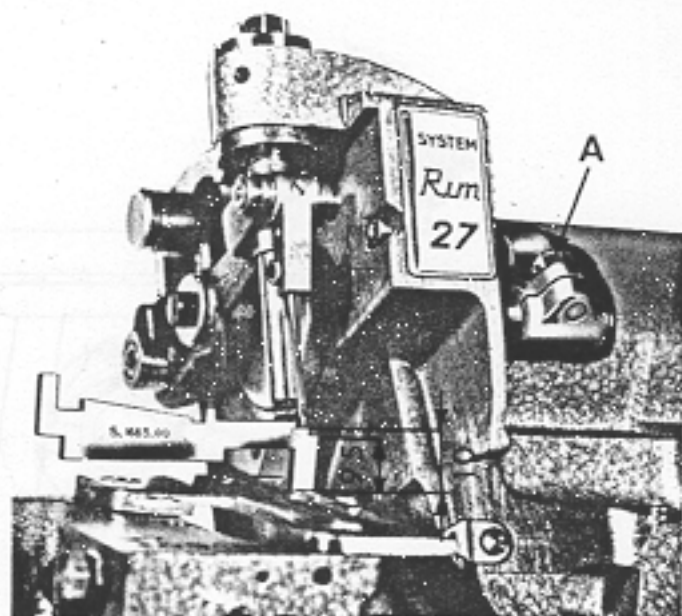

fig. 3

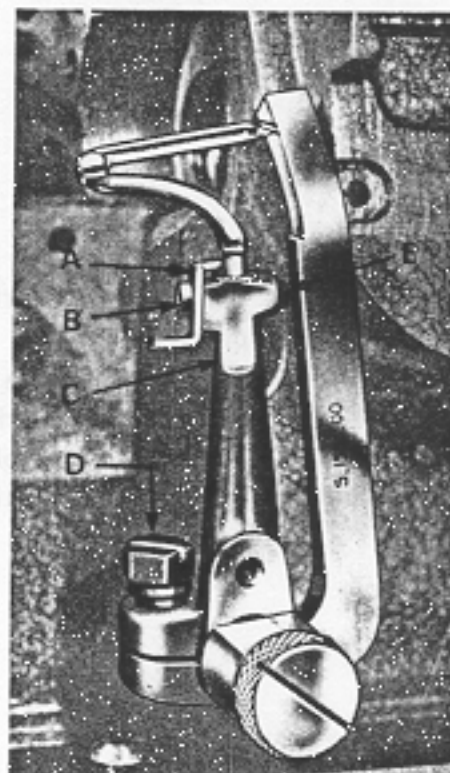

fig. 4

### 4. Setting lower looper (fig. 4).

#### Setting height

- Loosen screw E.
- Firmly screw gauge S. 1555.00 into the lower looper shaft.
- Adjust looper height so that its point coincides with the lower notch on the gauge. For 228-00-04 and its derivatives, the looper point should coincide with the upper notch.
- Lightly lock looper with screw E.
- Set height of thread guide bracket 'A' by raising it to top of looper shank and lock by tightening up screw B.
- Remove gauge S. 1555.00.

#### Adjusting angle

- Slightly loosen screw D.
- Rest the gauge S. 1665.00 on the milled base as in fig. 5; obtain correct inclination by moving lever C and by rotating the looper (previously having only been held in its seating and not locked).
- The exact position corresponds to that given in the setting tables.
- Firmly tighten screw E (fig. 4).

#### Positioning the looper with respect to the needle fig. 6.

- With the looper hand to the left, check the figure given in the timing table.
- Move lever C up and down the shaft it rotates on. When moving from left to right the looper point should pass 0,2 mm. from the bottom of the needle groove.
- Firmly tighten screw D.

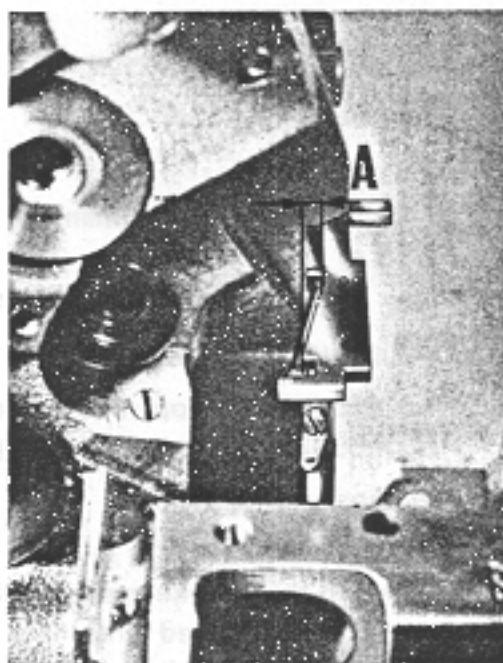

fig. 5

### 5. Setting upper looper.

**Note:** To obtain the figure of  $5/16'' - 23/64''$  in fig. 9 it is necessary to move lever E up or down, at the same time remembering that by doing this the distances in figs. 7 and 8 will increase or decrease.

- Slightly loosen screw B.
- Slightly loosen screw A.
- Adjust the crossing of the upper and lower loopers by rotating the upper until its point grazes the back of the lower.
- Check the settings shown in fig. 7-8-9 (setting table). The upper looper should graze the needle when passing from left to right.
- Should this condition not exist, slightly loosen screw D and push the whole assembly towards the interior or exterior of the machine without altering the settings previously obtained. Ensure perfect kinematic motion.
- Tighten screw D.
- Re-check the crossing of the two loopers and all the other settings.
- Tighten screws A and B.
- To finish off, make sure that all assemblies move freely.

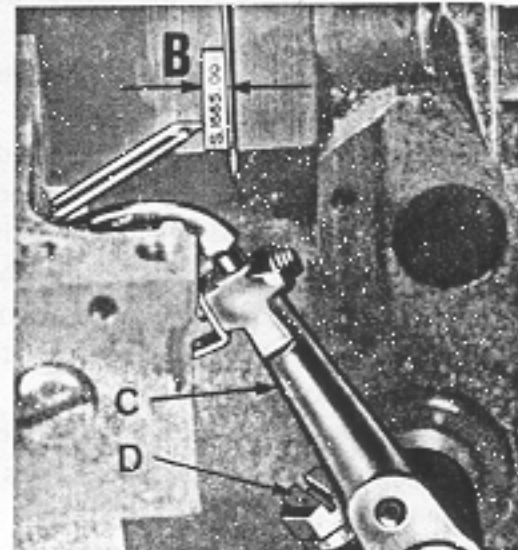

fig. 6

### 6. Attaching needle guards (fig. 10).

- Attach front needle guard A.
- With the needle at its lowest point, adjust the front needle guard so that the lower looper point grazes the needle.
- Tighten screw C.
- Attach rear needle guard B and adjust until close to the needle, still in the low position.
- Tighten screw D.

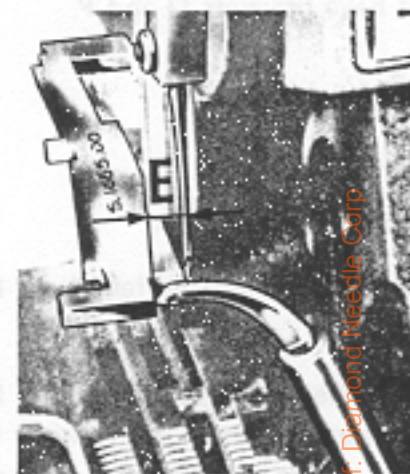

fig. 7

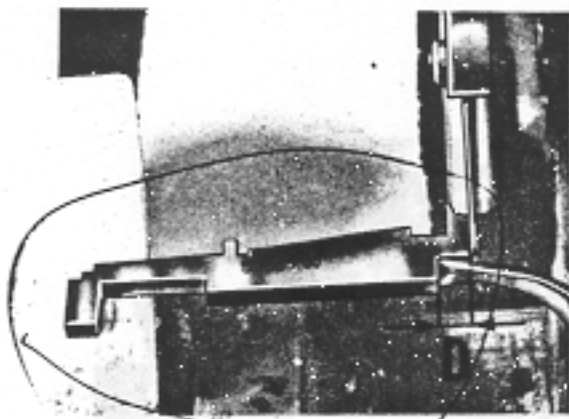

fig. 8

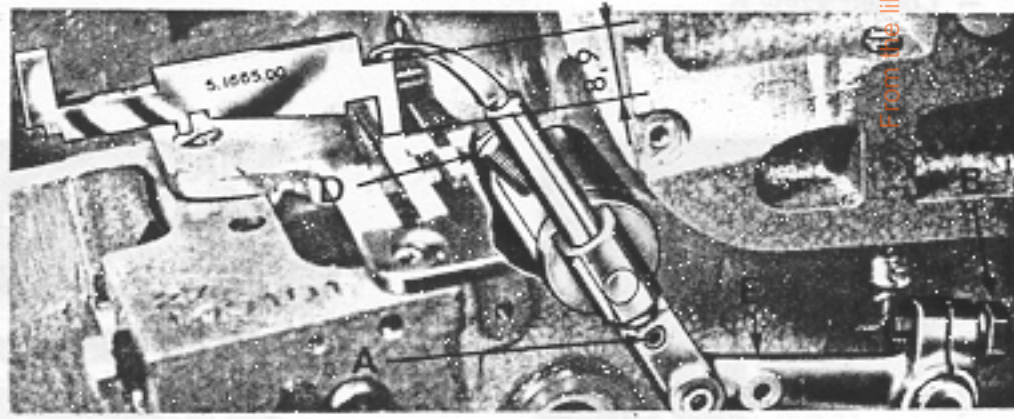

fig. 9

- It must be checked that the needle will not get broken during operation due to any bending causing it to hit the lower looper. To do this, bend the needle towards the interior of the machine and ensure that the looper, when passing from left to right, touches the needle, without breaking it.
- Thread the needle, then bring it right down and gently push it against rear needle guard B.
- The thread should run freely. If it does not it means that the needle is too low and the thread is being caught between the needle and the needle guard.

**Note:** The looper point should pass through the lower part of the groove on its right hand run, and through the upper part on its left hand run.

- For hard synthetic materials, make the needle bend more against the needle guard.

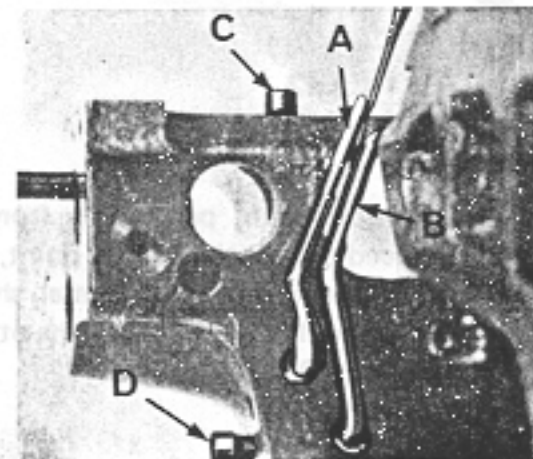

fig. 10

### 7. Fitting the lower knife (fig. 11).

- Fix bracket P to the knife holder with screw Q.
- Insert knife D into its seat.
- The cutting edge of the knife should not protrude above the surface of the plate.
- Tighten screw A.
- With the needle in the lowest position, slide bracket O towards the needle guard and lock bush L and washer G with screw F.
- Ensure that knife holder C slides freely and then adjust it in relation to the width of stitching required.
- Lightly tighten screw N.
- With the needle in the lowest position move bracket P towards front needle guard and lock with screw Q.
- Having positioned the upper knife in contact with the lower, loosen screw N. Spring M, with pin H, creates correct contact pressure between the knives.
- Rest a finger on screw A and thus exert a very light pressure to lock screw N.
- This pressure must be light in order not to cause strong friction between the two knives and their consequent damage.

Note: The following sub-classes:

228-00-05 228-00-03 228-00-08 and their derivatives do not have brackets O and P.

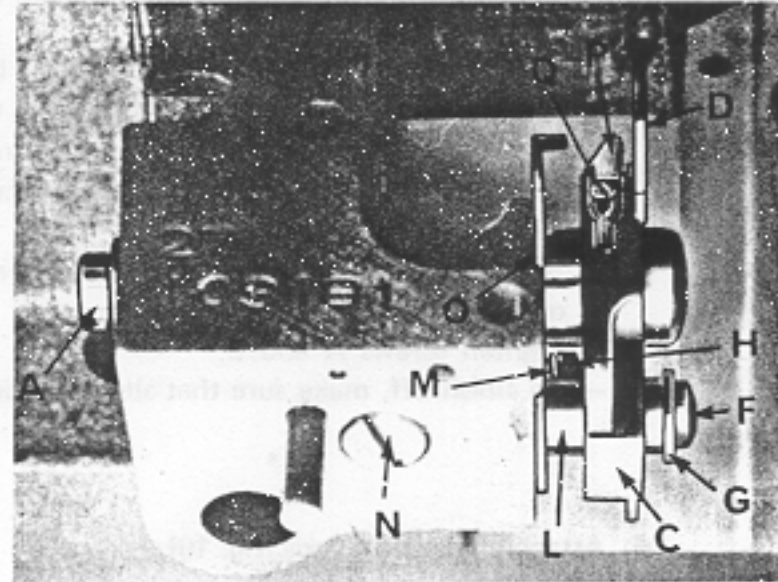

fig.11

### 8. Fitting and adjusting feed dogs (figs. 12 and 13).

- Fit the rear feed dogs C and D (fig. 12) and match the feed dog slides.
- Inserting a small screw driver through the threaded holes in the slides, tighten, but not completely, screw F, by means of the groove in its point.
- Fit the front differential feed dog E with screw G but do not lock (fig. 13).
- Loosen screw A.
- Adjust the feed dog inclination by rotating the eccentric B.

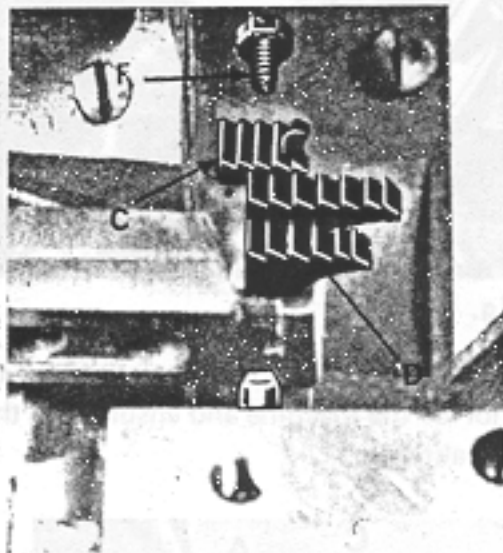

fig.12

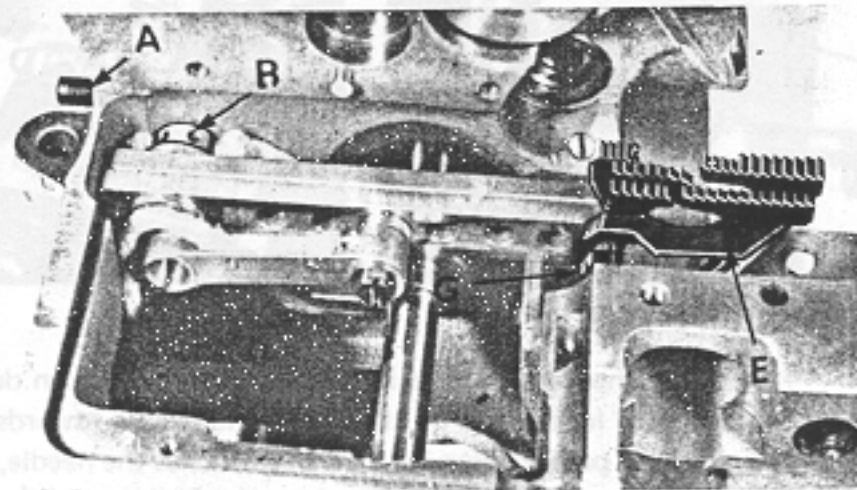

fig.13

- The feed dog teeth, protruding from the needle plate, should be perfectly parallel with this plate.
- With the feed dogs at the highest point, the distance between their teeth and the plate surface, measured on the front of the feed dog differential, should be  $3/64$ ".
- Feed dog C should be lower than the other two feed dogs.
- Lock screws F, G and A.

9. Feed (fig. 14).

**Note:** The machines illustrated in this manual are supplied with the feed adjusted to suit the work for which the machines are destined.

Should it ever be desired to alter the feed, then procede as follows:

- Substitute eccentric A or eccentric B, or both A and B. For eccentric substitution, according to the length of stitch, consult the appropriate tables. Use extractor drawing No. 280-715.

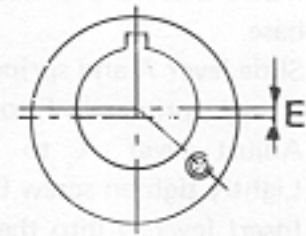
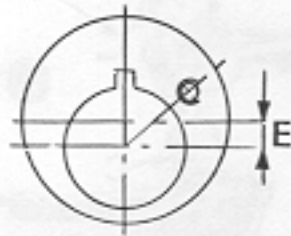

ECCENTRICITY E	No. stitches per inch	DRAWING No.
2,57 ± 0,03	3,5	280-0451/3,5
2,12 ± 0,03	4	280-0451/4
1,49 ± 0,03	5	280-0451/5
1,06 ± 0,03	6	280-0451/6
0,76 ± 0,03	7	280-0451/7
0,53 ± 0,03	8	280-0451/8
0,36 ± 0,03	9	280-0451/9
0,22 ± 0,03	10	280-0451/10
0 ± 0,03	12	280-0451/12

ECCENTRICITY E	No. stitches per inch	DRAWING No.
0,15 ± 0,02	14	280-0461/14
0,26 ± 0,02	16	280-0461/16
0,35 ± 0,02	18	280-0461/18
0,42 ± 0,01	20	280-0461/20
0,48 ± 0,01	22	280-0461/22
0,53 ± 0,01	24	280-0461/24
0,57 ± 0,008	26	280-0461/26
0,6 ± 0,008	28	280-0461/28
0,63 ± 0,005	30	280-0461/30
0,65 ± 0,005	32	280-0461/32
0,68 ± 0,005	34	280-0461/34
0,7 ± 0,005	36	280-0461/36
0,74 ± 0,005	40	280-0461/40
0,76 ± 0,005	44	280-0461/44
0,8 ± 0,005	50	280-0461/50
0,84 ± 0,005	60	280-0461/60
0,87 ± 0,005	70	280-0461/70
0,88 ± 0,005	74	280-0461/74

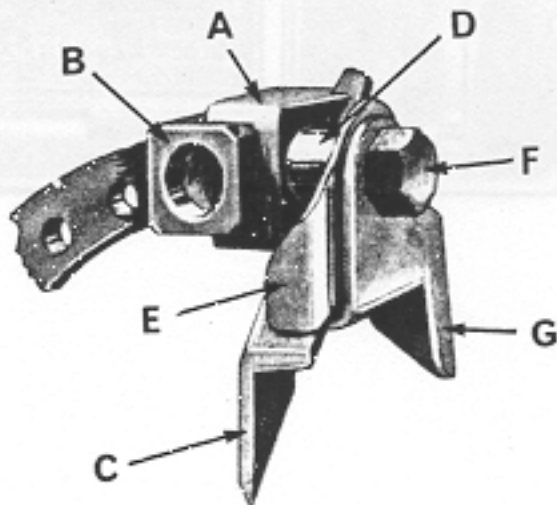

fig. 15

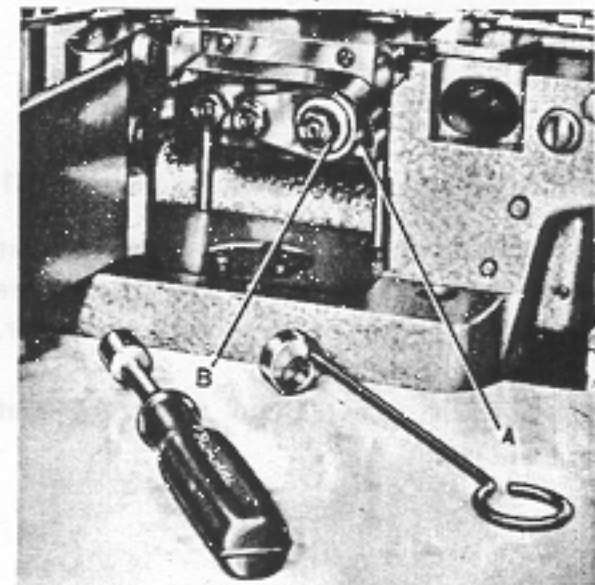

fig. 14

10. Fitting upper knife (fig. 15).

- Fit upper knife C into its seat in block A.
- Attach block D and brackets E and G with bolt F.
- Bracket E should be very near the cutting plane of knife C.
- When knife C is at the bottom of its stroke, its cutting edge should be 1/32" below the cutting edge of the lower knife.
- To obtain this, adjust knife C in its inclined seat and block A on the body of the upper knife holder B.
- Lock bolt F and then make sure that when the upper knife reaches the bottom of its stroke it does not touch the front needle guard.

e) Locking and adjusting presserfoot lever (fig. 16).

- Slide the lever shaft L into bush C to which lever D is hinged.
- Insert shaft L and bush C into the appropriate hole in the base.
- Slide lever A and spring E onto shaft L.
- Attach spring clip F to end of shaft L.
- Adjust lever A to eliminate axial play of shaft L.
- Lightly tighten screw B.
- Insert lever D into the guiding fork with the needle at top dead center.
- Connect lever A to the rod joined to the presserfoot raising pedal.
- When the pedal is depressed there should be some free play before lever D is acted upon.

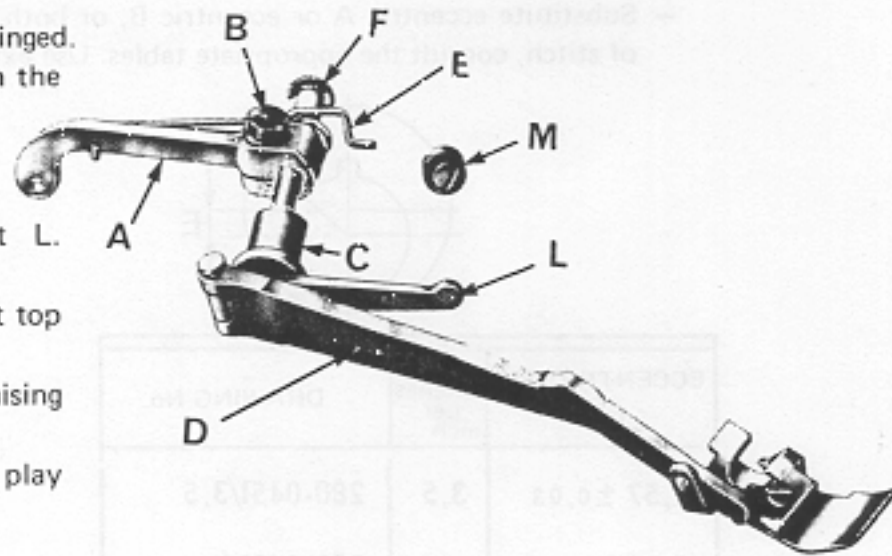

fig.16

- Adjust the screw in the base under lever A until this raises the presserfoot to the required position.
- Ensure that when the upper looper is in movement it does not touch the presserfoot tongue when this is in its highest position. A better guard against the upper looper and the presserfoot tongue hitting, is supplied by adjusting the eccentric washer M which is under lever D and attached to the side cover.
- Lock screw B.

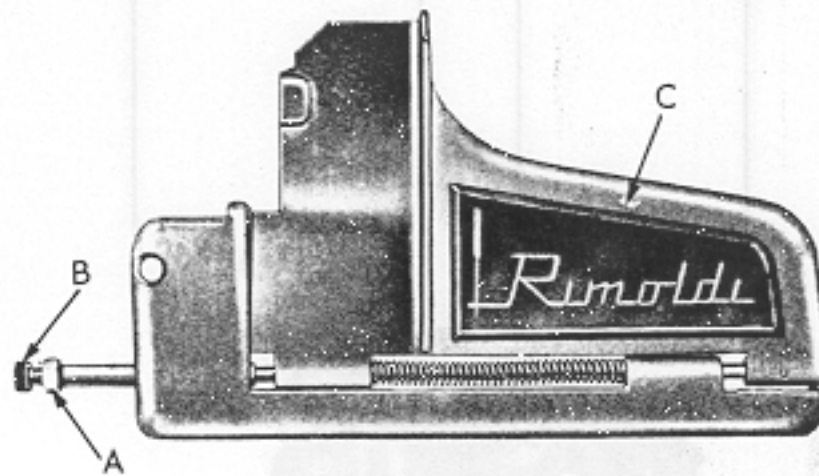

fig.17

f) Adjusting the front cover plate (fig. 17).

- Adjustment is carried out with the plate closed.
- The movable part C should not interfere with the front needle guard or the lower knife holder.
- Slacken-off nut A.
- Adjust screw B to move the plate to left or right.
- Lock nut A.

g) Adjusting needle thread take-up

- When working with very hard materials adjust the needle thread take-up 270-274/2 by moving it forward, that is towards the operator.

From the library of: Diamond Needle Corp



## ELECTRICAL EQUIPMENT FOR LUBRICATION CONTROL (PRESSURE SWITCH)

### h) Dismantling and replacing the pressure switch

- Remove the sump from the base and empty the oil.
- Remove the screw fixing the pressure switch bracket to the sump.
- Remove the two screws holding the cable end.
- Remove the plastic tube from the pressure switch which connects to the rubber union.
- Remove the support bracket and fix it to the new pressure switch.
- Attach the cable end with the screws, slide the plastic tube into the pressure switch and replace in sump with appropriate screw.
- Replace the sump and fill with oil as described on page 11 para. c.

### Changing the pressure switch bulb.

- Carry out operations 1 and 2 as explained for the substitution of the pressure switch.
- Remove tube, extract the bulb, which has a bayonet fitting, and replace with a new one.
- Re-attach the tube, position the pressure switch in the sump and attach with the screws.
- Replace sump and fill with oil as explained on pag. 11 para. c.

### Electrical connection of pressure switch on Zefir motors.

- Plug the connecting cable into the pick-up socket and plug the other end into the 12 V. light socket on the motor.

Note: if connection has to be made to a motor not equipped with a light socket, but equipped with a 12 V. take-off in the connection box, procede as follows:

- Cut a piece of cable to about 5" length and to one end attach a Mignon socket type 13 and to the other the pins of the 12 V. light voltage.
- Plug the connecting cable into the pick-up socket and plug the other end into the Mignon socket.

### Regulating flow of lubricating oil through the main shaft. (fig. 18).

- Remove cap
- Adjust index B with a screw driver. (Movement towards the C engraved on the plate, decreases the oil flow, towards the letter A increases flow.

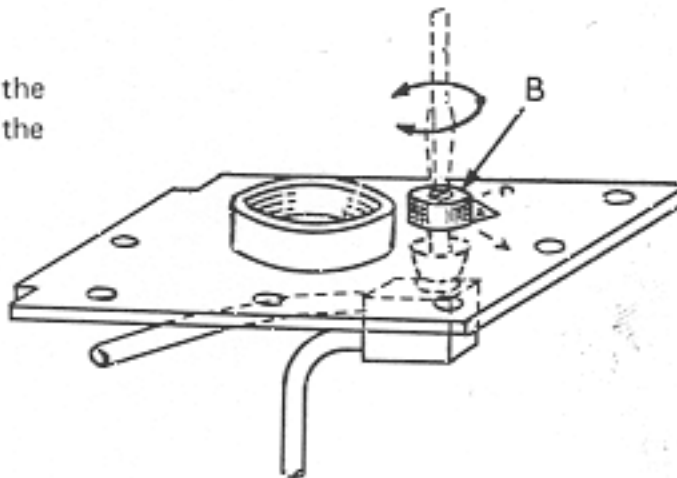
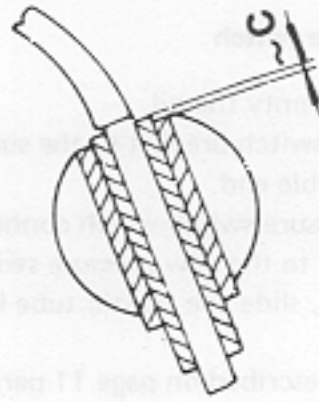

fig.18

TABLE OF SETTINGS

ELECTRICAL EQUIPMENT FOR LUBRICATION CONTROL (PRESSURE SWITCH)



HEAD SIMBOLS	A	B	C	D	E
228-00-01 = 228-00-04 = 228-00-05 = 228-00-11 = 228-00-12 = 228-01-01 = 228-01-02 = 228-01-03 = 228-10-01 = 228-10-02 = 228-10-03 = 228-10-05 = 228-10-06 = 228-10-07 = 228-28-01 = 228-28-02 =	2,5	1,5	0,8	4,5	3,5
228-00-02 = 228-00-03 = 228-00-06 = 228-00-08 =	2,3	1,5	0,8	-	5
228-00-07 = 228-28-07 =	2,3	1,5	0,8	5	-

From the library of: Diamond Needle Corp

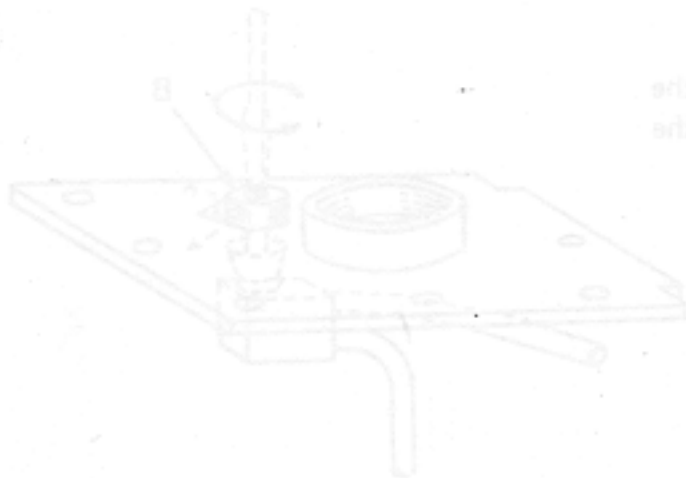

Regulating flow of lubricating oil through the main shaft. (Fig. 18).

- Remove cap.
- Adjust index B with a screw driver. (Movement towards the C engraved on the plate, decrease the oil flow, towards the letter A increases flow.)

II. USE

a) Threading

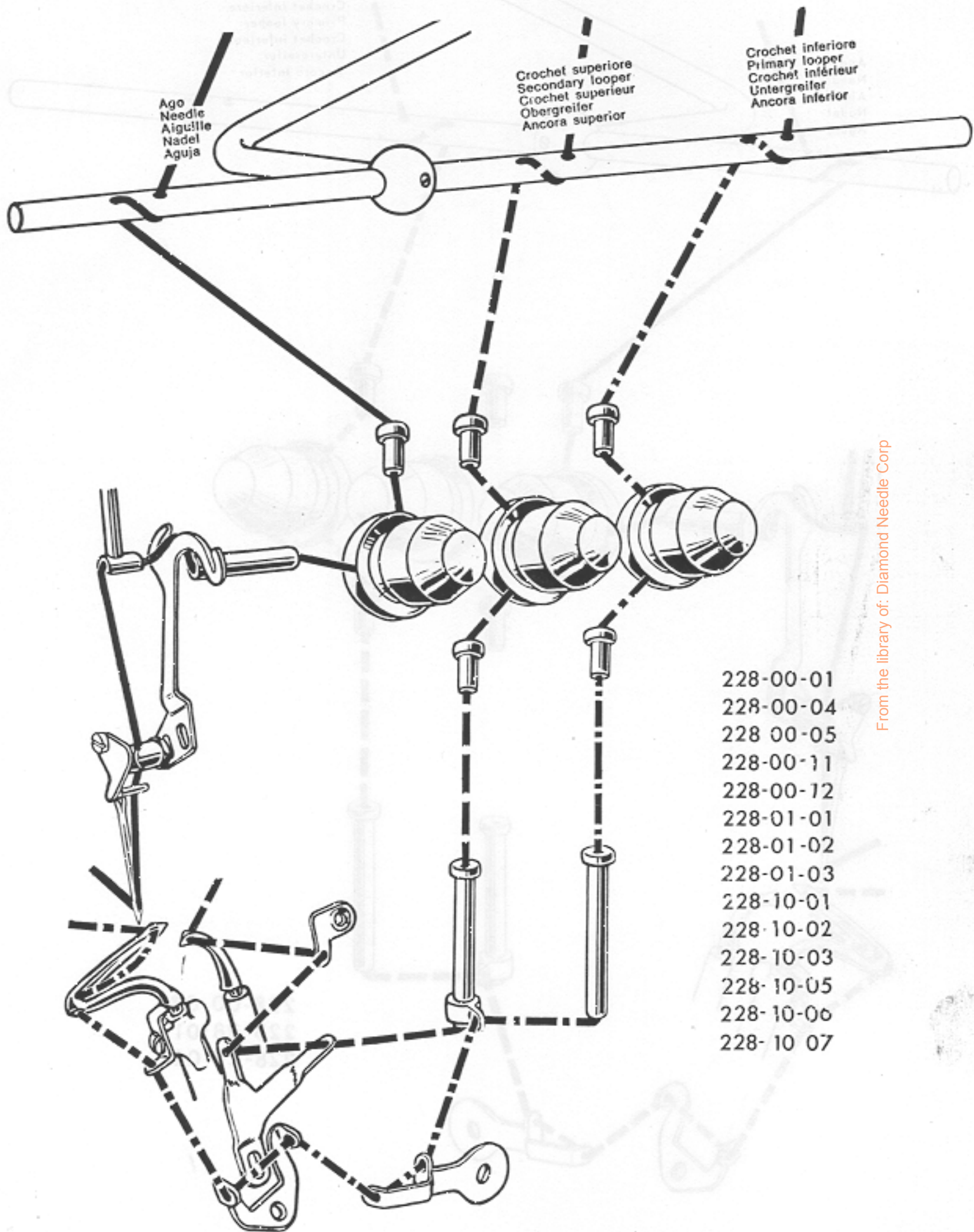

From the library of: Diamond Needle Corp

INDEX

INTRODUCTION

5	I - HEAD IDENTIFICATION
5	II - TECHNICAL DATA OF CLASS
5	III - TECHNICAL DATA OF SUB-CLASSES

INSTRUCTIONS

11	I - INSTALLATION AND SETTING UP
11	a - Preparation of tool
11	b - Transmission assembly
11	c - Lubrication
11	d - Assembly and adjusting sewing feet
15	e - Adjusting and locking pressure foot
15	f - Setting foot over foot
15	g - Check foot and adjustment
17	h - Electric foot and adjustment
19	II - USE
19	a - Thread
19	b - Changing the needle
23	c - Setting the pressure foot
23	d - Setting of tension disc
23	e - Stitch length adjustment
23	f - Sew with adjustment
25	g - Protection to prevent jamming of machine
29	III - MAINTENANCE
29	a - Every day
29	b - Every week
29	c - Every three months
29	d - Sharpening the knives

SPARE PARTS CATALOGUE

29	I - HOW TO USE THIS CATALOGUE
29	a - Introduction
29	II - HOW TO ORDER
29	a - All parts
29	b - Needles
29	III - TABLES
29	IV - NUMERICAL INDEX OF PARTS

From the library of: Diamond Needle Corp

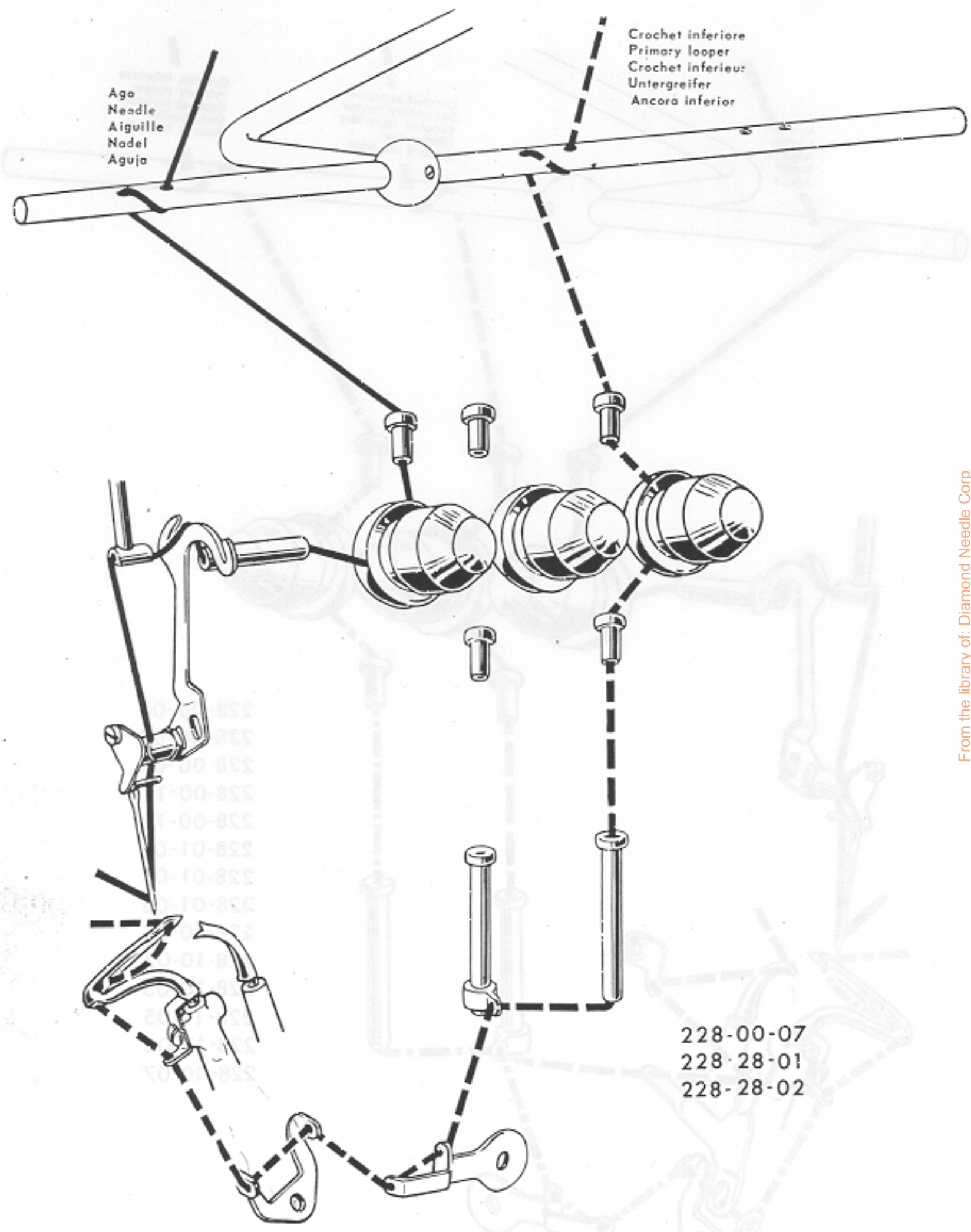

From the library of: Diamond Needle Corp

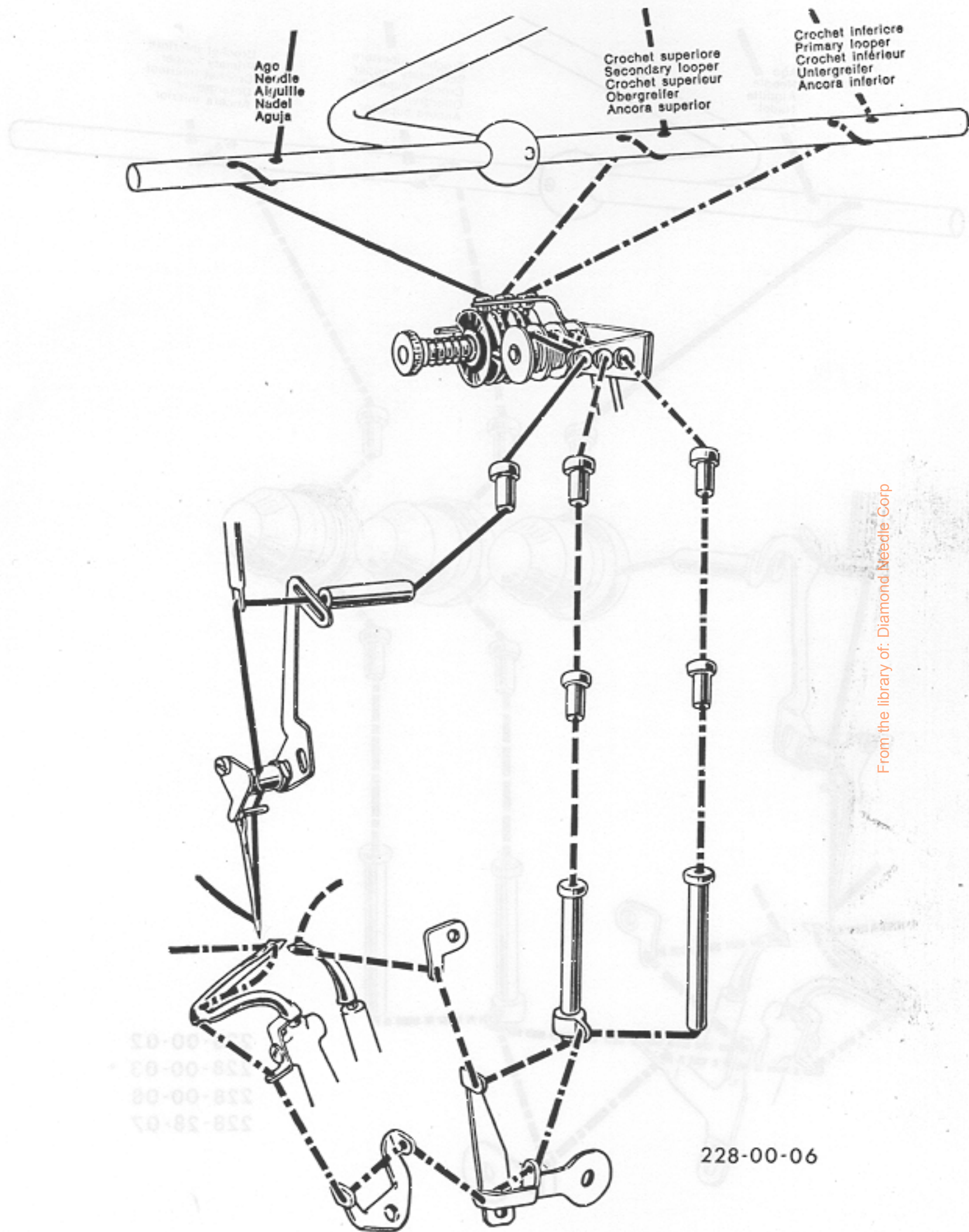

From the library of: Diamond Needle Corp

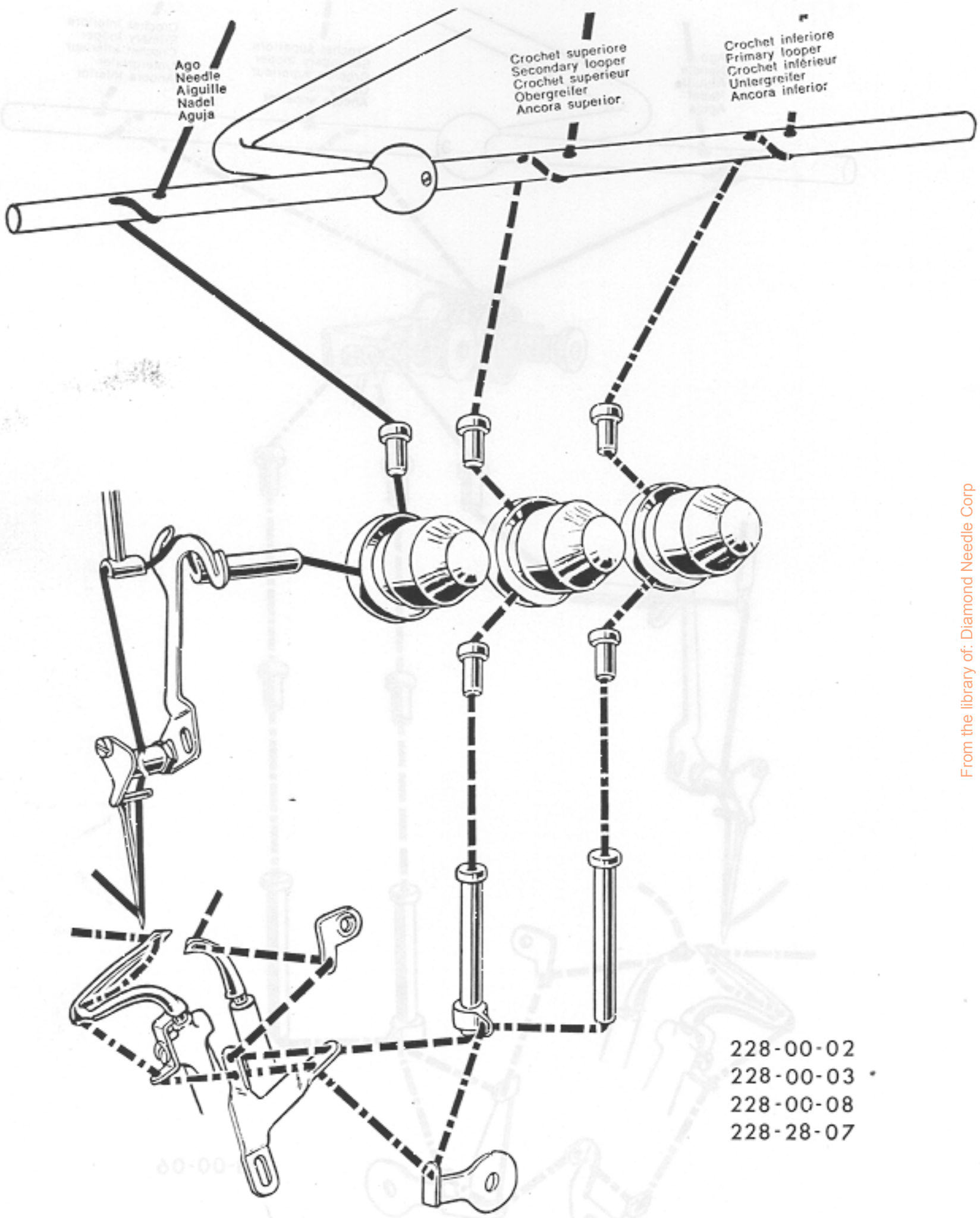

From the library of: Diamond Needle Corp

228-00-02  
 228-00-03  
 228-00-08  
 228-28-07

#### b) Changing the needle

1. Switch off the motor
2. Depress the pedal which starts the motor to ensure the machine is completely off.
3. Move the needle to top dead center.
4. Press lever B right down (fig. 19).
5. Remove the presserfoot from its working position.
6. Slacken the needle locking screw half a turn with screw driver 1161/2.
7. Remove the needle.
8. Fit new needle.
9. The notch through which the looper passes should face towards the rear needle guard, that is towards the interior of the machine.
10. Using the tweezers supplied ensure that the needle touches the end of the needle holder.
11. Tighten the locking screw being careful not to alter the position of the needle.
12. Do not over-tighten.

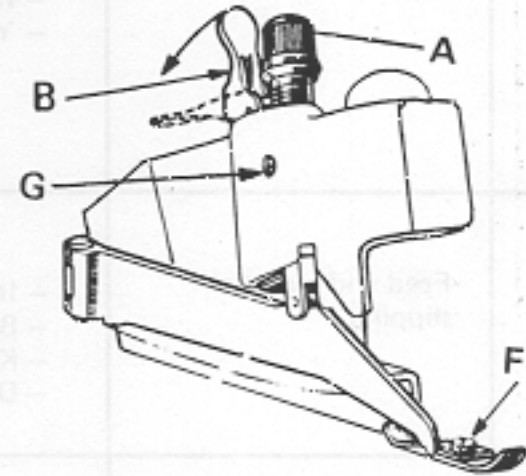

fig. 19

#### c) Positioning and adjusting presserfoot pressure (fig. 19).

1. Check correct positioning of presserfoot
2. The needle should pass between the presserfoot shoe and tongue.
3. To adjust presserfoot slacken off screw F.
4. Center the presserfoot in the correct position and lock F.
5. To increase or decrease the presserfoot pressure, slacken off screw G with spanner 633-742 and adjust knob A.
6. Lock knob A with screw G.

#### d) Tension adjustment

1. Tighten the tensioners sufficiently to permit a regular stitch formation.
2. Never tighten too much

#### e) Stitch length adjustment (fig. 14).

For stitch length adjustment see para. a) 9 Feed, pag. 15.

#### f) Adjustment of seam width.

The seam width can only be varied to a very limited extent after which the needle plate has to be changed. To vary the width within these fine limits proceed as follows:

1. Slacken off screw N in the lower knife holder (fig. 11).
2. Slacken off screw F (fig. 15).
3. Move upper knife support A (fig. 15) to right or left till desired seam width is obtained.
4. Lock screw F (fig. 15).
5. Lower knife holder re-setting should be carried out in accordance with the instructions in para. a) 7.



**g) Faults due to improper handling of the machine**

n°	FAULT	PROBABLE CAUSE
1	Irregular stitch	<ul style="list-style-type: none"> <li>- Tensioners badly adjusted</li> <li>- Thread take-ups badly adjusted</li> <li>- Incorrect threading</li> <li>- Yarns not gauged</li> </ul>
2	Feed and material slipping	<ul style="list-style-type: none"> <li>- Insufficient presserfoot pressure</li> <li>- Bad adjustment of feed dog height and inclination</li> <li>- Knives need sharpening</li> <li>- Differential badly adjusted</li> </ul>
3	Skip stitching	<ul style="list-style-type: none"> <li>- Upper or lower looper badly adjusted with respect to needle consequently blunting looper.</li> <li>- Loopers too far apart when crossing</li> <li>- Loopers too close when crossing with consequent blunting.</li> <li>- Front needle guard too far from needle</li> <li>- Needle badly positioned</li> </ul>
4	Thread breaking	<ul style="list-style-type: none"> <li>- Tensions too tight</li> <li>- Thread wound irregularly on the reel.</li> </ul>
5	Needle breaking	<ul style="list-style-type: none"> <li>- Bent needle</li> <li>- Needle badly fitted</li> </ul>
6	Puncturing of material	<ul style="list-style-type: none"> <li>- Blunt needle</li> <li>- Needle size not suitable to throat plate</li> <li>- Needle with unsuitable point</li> </ul>
7	Loss of oil	<ul style="list-style-type: none"> <li>- Screw holding sump to base not tightened enough</li> <li>- Sump plug not screwed up properly</li> <li>- Sump gasket badly fitted.</li> </ul>
8	Lack of lubrication	<ul style="list-style-type: none"> <li>- Oil level too low</li> <li>- Drive belt badly fitted</li> <li>- Upper tube clogged</li> <li>- Lubrication pump filter blocked.</li> </ul>

From the library of: Diamond Needle Corp

### III. MAINTENANCE

#### a) Every day

Briefly clean all machine parts relating to feed and stitch formation.

#### b) Every week

1. Remove needle plate and clean the feed dogs, needle guards and loopers.
2. Open front cover plate and carefully clean inside
3. Carefully clean inside the plate covering the needle movement assembly.

#### c) Every three months

1. Using the spanner supplied, remove the sump drain plug and drain off oil completely.
2. Remove screw 007-L-20 which attaches filter to plug.
3. Extract filter and clean by immersing in petrol.
4. Air blast filter and sump plug.
5. Soak felt with clean oil.
6. Replace sump plug.
7. Refill machine with 1 3/4 pts. of new VR. 604 oil.



fig. 19

#### IMPORTANT

In operation 1 para. c) do not completely remove the plug to begin with, so that most of the oil runs out through the side holes in the plug (fig. 19).

#### d) Knife sharpening

1. When sharpening the knives use the RIMOLDI sharpener and special block which guarantees exact sharpening angle. This block is supplied on request.

#### e) Instructions for removal of cam shaft

- Necessary tools supplied on request only.
- Pliers model S. 0560/00.
- Pliers model S. 0459/00.
- Extractor S. 0416/00

#### IMPORTANT

It is absolutely essential that the principal components of the crank-shaft/con-rod assembly are replaced in their original positions. To this aim proceed as follows:

- Replace the T flanges with the lubrication hole towards the bottom.
- Leave the screws holding the con-rod caps in their holes.
- Con-rods J and L are distinguishable one from the other by means of a 2 stamped on the top surface of L and three lines on J.
- The con-rod caps are engraved with similar markings and should be matched to the respective con-rod. Both marks should be on the same side.
- The position of con-rod N is given by the drawing number which should be on the pulley side.
- Carefully follow the cup spring assembly order.

III. MAINTENANCE  
**SEQUENCE OF OPERATIONS (fig. 20).**

1. Open the side cover.
2. Remove screw D.
3. Using extractor 280-715 extract the eccentrics A and B.
4. Remove con rod caps N, O, J, L.
5. Remove screw Z.
6. Remove pulley cover Y.
7. Slacken off hexagonal screw X.
8. Remove washer W.
9. Extract pulley V.
10. Remove flange T.
11. Remove spacer U.
12. Remove springs S.
13. Extract spring ring P using pliers S. 0459/00 slightly turning the shaft to the right.
14. Extract the shaft.

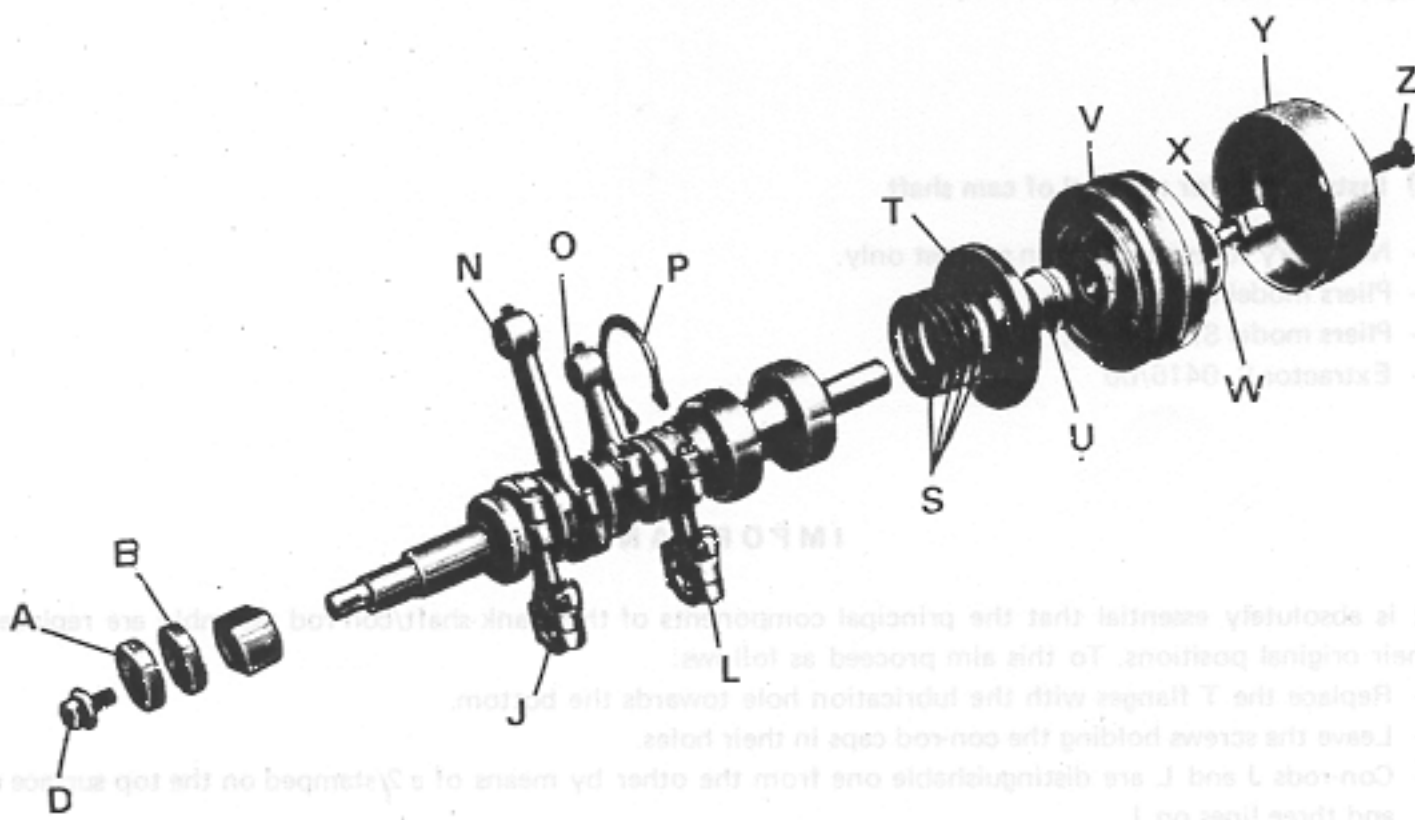

fig. 20

# SPARE PARTS CATALOGUE

From the library of: Diamond Needle Corp

SPARE PARTS CATALOGUE

From the library of: Diamond Needle Corp

## I. HOW TO USE THIS CATALOGUE

### a) Introduction

1. This spare parts catalog is made up of a series of tables illustrating the various parts or assemblies which make up the basic head and its sub-classes.
2. In order to make the use of this catalogue easier, the table index shows the position of each assembly inside the head.
3. The conversion assemblies of the basic head and its sub-classes are illustrated in single tables.
4. In the tables, the numbers which identify the sub-classes are printed at top right of page in black.
5. On each table the various components of the assembly illustrated, are cross-referenced by a number. The assemblies, whose components cannot be supplied separately, are cross-referenced by a capital letter. Parts and equipment not normally with the machines but which can be supplied on request, are given at the bottom of each table and are illustrated complete with all their particulars at the end of the book.
6. The catalogue has a general numerical index giving the cross-reference numbers of all component parts of the machine and listing the table on which the parts are illustrated.

## II. HOW TO ORDER SPARE PARTS

### a) All parts

To ensure immediate dispatch of required spare parts, the following instructions should be carefully followed:

1. Quote the serial number of the head.
2. Quote the drawing number of the part required.
3. Give the full name of the part required.
4. The quantity.

### IMPORTANT

The RIMOLDI Company likes to analyse any cases of breakage, wear or irregularities arising in parts manufactured by them. For this reason they kindly ask you to return such pieces along with the order for spare parts.

### b) Needles only

1. Only straight system RIM 27 needles should be used on the machines illustrated in this manual.
2. The needle system and size are marked on the needle shank.
3. The size indicates the average diameter expressed in hundredths of a millimeter calculated on the blade of the needle.
4. The system and size are also shown on the packets containing RIMOLDI needles.
5. When ordering always give the system and size of the needle required (e.g. n. 100 needles size 90 system RIM 27).
6. In case of doubt send a sample needle or an empty packet of the type required.
7. For stitching elastic or elasticised materials there are ball point needles classified SKU.

# INTRODUCTION

From the library of: Diamond Needle Corp

## I. HOW TO USE THIS CATALOGUE

### a) Introduction

1. This spare parts catalogue is made up of a series of tables illustrating the various part assemblies which make up the basic head and its sub-class.
2. In order to make the use of this catalogue easier, the table index shows the position of each assembly inside the head.
3. The conversion assemblies of the basic head and its sub-classes are illustrated in spare tables.
4. In the tables, the numbers which identify the sub-classes are printed at the right of each line.
5. On each table the various components of the assembly illustrated are cross-referenced by a number. The numbers whose components cannot be supplied separately are cross-referenced by a capital letter. Parts and equipment not normally with the machines but which can be supplied on request, are given at the bottom of each table and are illustrated together with their particulars at the end of the book.
6. The catalogue has a general numerical index giving the cross-reference numbers of all component parts of the machine and listing the table on which the parts are illustrated.

## II. HOW TO ORDER SPARE PARTS

### a) All parts

- To ensure immediate dispatch of required spare parts, the following instructions should be carefully followed:
1. Quote the serial number of the head.
  2. Quote the drawing number of the part required.
  3. Quote the full name of the part required.
  4. The quantity.

### IMPORTANT

The RIMOLDI Company likes to analyse any case of breakage, wear or irregularities arising in parts manufactured by them. For this reason they kindly ask you to return such pieces along with the order for spare parts.

### b) Needles only





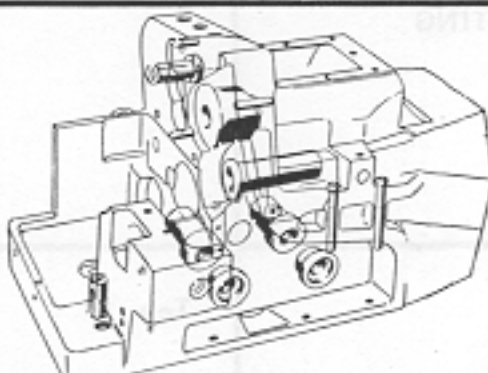
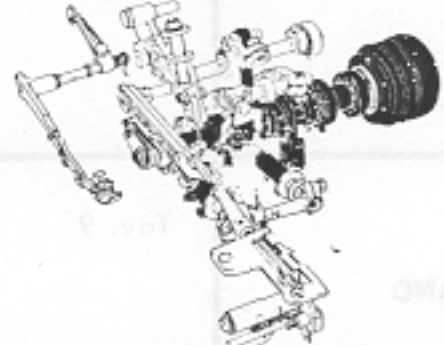
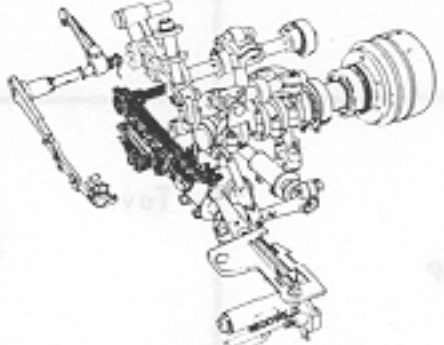
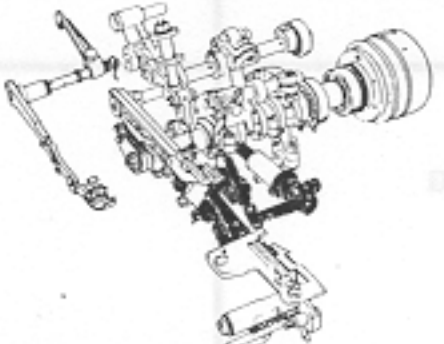
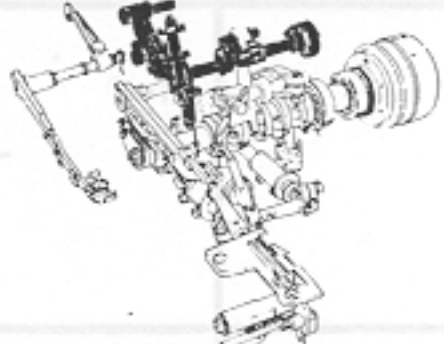
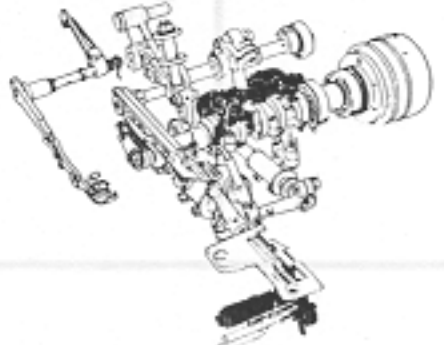

1. Only straight system RIM 27 needles should be used on the machines illustrated in this manual.
2. The needle system and size are marked on the needle shank.
3. The size indicates the average diameter expressed in hundredths of a millimeter calculated on the blade of the needle.
4. The system and size are also shown on the packets containing RIMOLDI needles.
5. When ordering always give the system and size of the needle required (e.g. n. 100 needle size 90 system RIM 27).
6. In case of doubt send a sample needle or an empty packet of the type required.
7. For stitching elastic or elasticated materials there are ball point needles classified SKU.

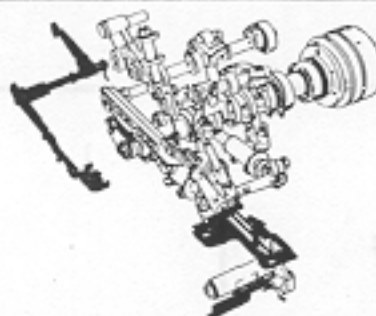

# INDEX OF TABLES

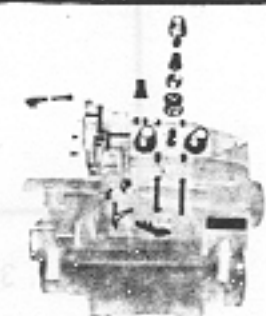
<p>BUSHES – THREAD GUIDES STUDS PRESSED INTO THE BASE</p>	<p>Tav. 1</p> 
<p>MAIN SHAFT WITH CON-RODS</p>	<p>Tav. 2</p> 
<p>DIFFERENTIAL ASSEMBLY</p>	<p>Tav. 3</p> 
<p>SHAFTS AND CON-RODS OPERATING LOOPER</p>	<p>Tav. 4</p> 
<p>NEEDLE DRIVE MECHANISM</p>	<p>Tav. 5</p> 
<p>UPPER AND LOWER KNIFE MECHANISM</p>	<p>Tav. 6</p> 

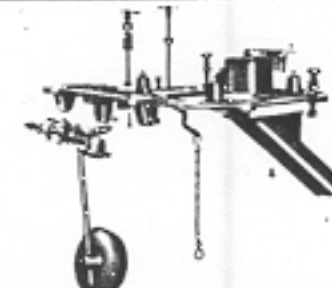
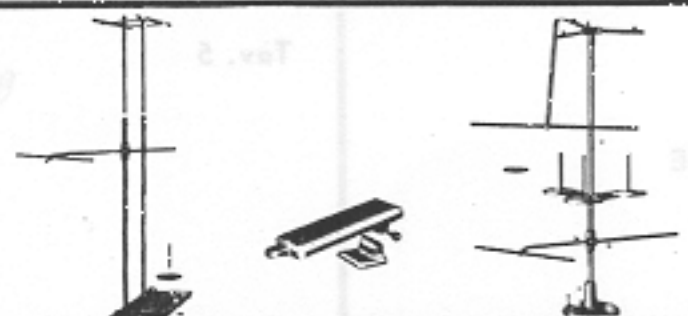
From the library of: Diamond Needle Corp

<p>PRESSERFOOT LIFTING MECHANISM — NEEDLE PLATE</p>	<p>Tav. 7</p> 
<p>CASING — WORK PLATE</p>	<p>Tav. 8</p> 
<p>THREAD GUIDES AND TENSIONERS</p>	<p>Tav. 9</p> 
<p>SUMP AND OIL PUMP</p>	<p>Tav.</p> 
<p>MACHINE MOUNTING BRACKET AND KNEE CONTROL</p>	<p>Tav.</p> 
<p>REEL HOLDERS AND PEDAL</p>	<p>Tav.</p> 
<p>ACCESSORIES</p>	<p>Tav.</p> 

From the library of: Diamond Needle Corp

HEAD 228-00-02	Tab. 14	HEAD 228-10-01	Tab. 26
" 228-00-03	Tab. 15	" 228-10-02	Tab. 27
" 228-00-04	Tab. 16	" 228-10-03	Tab. 28
" 228-00-05	Tab. 17	" 228-10-05	Tab. 29
" 228-00-06	Tab. 18	" 228-10-06	Tab. 30
" 228-00-07	Tab. 19	" 228-10-07	Tab. 31
" 228-00-08	Tab. 20	" 228-28-01	Tab. 32
" 228-00-11	Tab. 21	" 228-28-02	Tab. 33
" 228-00-12	Tab. 22	" 228-28-07	Tab. 34
" 228-01-01	Tab. 23	TABLE W1 (100)	Tab. 35 Tab. 36
" 228-01-02	Tab. 24	TABLE X1 (101)	Tab. 37
" 228-01-03	Tab. 25	PARTS ON REQUEST	Tab. 38 Tab. 39

From the library of: Diamond Needle Corp

Tap 29	HEAD 528-00-03	Tap 14	HEAD 528-10-01	Tap 29
Tap 27	528-00-03	Tap 18	528-10-02	Tap 27
Tap 28	528-00-04	Tap 18	528-10-03	Tap 28
Tap 28	528-00-06	Tap 17	528-10-05	Tap 28
Tap 28	528-00-08	Tap 18	528-10-04	Tap 28
Tap 28	528-00-07	Tap 18	528-10-05	Tap 28
Tap 28	528-00-08	Tap 20	528-10-01	Tap 28
Tap 28	528-00-11	Tap 21	528-10-02	Tap 28
Tap 28	528-00-13	Tap 23	528-10-03	Tap 28
Tap 28	528-01-01	Tap 23	TABLE W1 (100)	Tap 28
Tap 28	528-01-02	Tap 24	TABLE X1 (10)	Tap 28
Tap 28	528-01-03	Tap 25	PARTS ON REQUEST	Tap 28

From the library of: Diamond Needle Corp

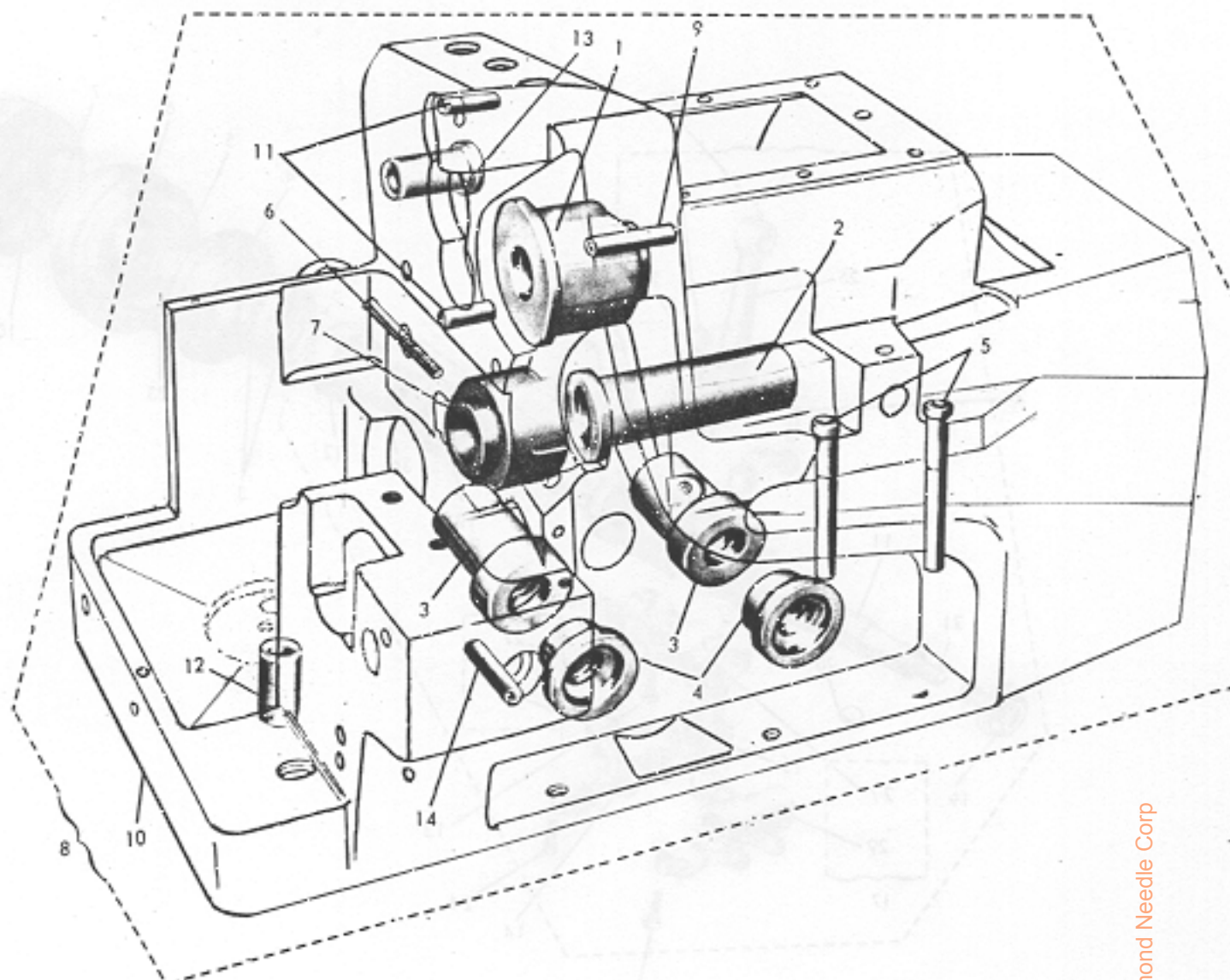

From the library of: Diamond Needle Corp

REF. N°	PART. N°	DESCRIPTION	QUANT.	REF. N°	PART. N°	DESCRIPTION	QUANT.
1	270-016	bush, shaft	1	9	270-264	thread guide needle	1
2	270-097/1	bush knife holder	1	10	280-002/1	base machine	1
3	270-058/2	bush rear	2	11	270-642	studs cover centering	2
4	270-057/1	bush front	2	12	280-830	tube oil	1
5	270-268	tubes thread guide	2	13	270-082/1	bush presserfoot lift	1
6	270-938	bolt bush	1	14	270-912	locking pin presserfoot work plate	1
7	280-010/3	bush main shaft	1				
8	G.280-002/2	base with bush and thread guides	1				

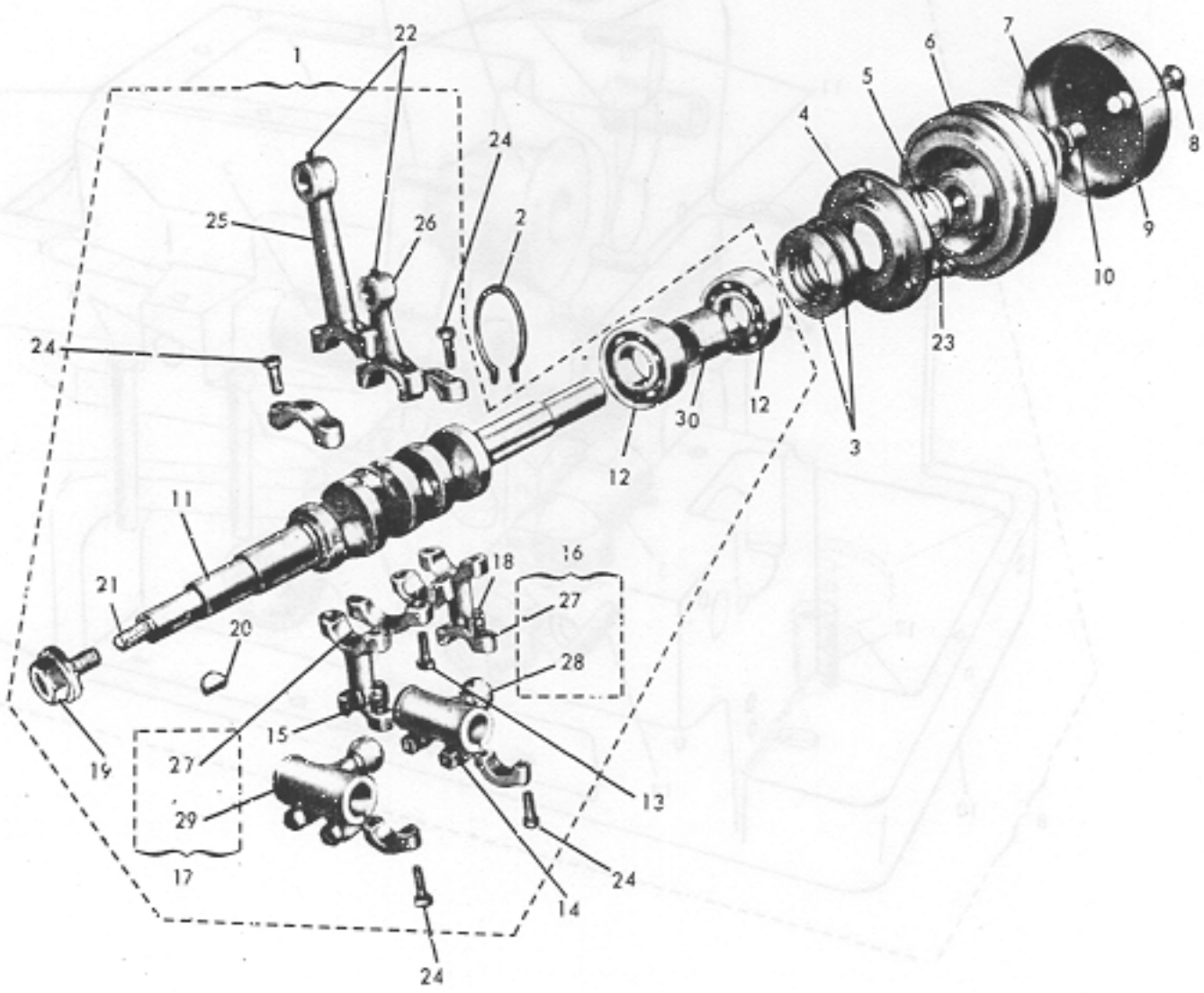

From the library of: Diamond Needle Corp

REF. N°	PART. N°	DESCRIPTION	QUANT.	REF. N°	PART. N°	DESCRIPTION	QUANT.
1	PM.280.009/4	main shaft complete	1	17	PM.270-059/1	con-rod with coupling	1
2	270-704	seeger ring for right bearing	1	18	270-062	guide con-rod	2
3	270-705	spring	4	19	280-925/1	bolt eccentric locking	1
4	270-620	flange right side	1	20	280-019	woodruff key	1
5	270-614	spacer right	1	21	092-D-26	wick for shaft	1
6	270-008/1	pulley	1	22	023-N-5,5	screw gudgeon pin locating	2
7	270-612/1	washer with guide	1	23	001-E-10	bolt flange	3
8	270-981	bolt pulley fixing	1	24	010-D-11,5	bolt for looper con-rod	8
9	128-608/5	cover pulley	1	25	280-012/3	con-rod needle bar	1
10	270-610	stud pulley	1	26	270-116/2	con-rod knife shaft	1
11	280-009/4	main shaft	1	27	270-061/2	con-rod upper looper	2
12	270-707	ball bearing right	2	28	270-060/1	coupling con-rod	1
13	010-H-13,7	bolt for con-rod 280-012/3 and 270-116/2	4	29	270-059/1	coupling con-rod	1
14	270-975	bolt coupling	4	30	270-613	spacer bearing	1
15	290-944	screw guide fixing	2				
16	PM.270-060/1	con-rod with coupling	1				

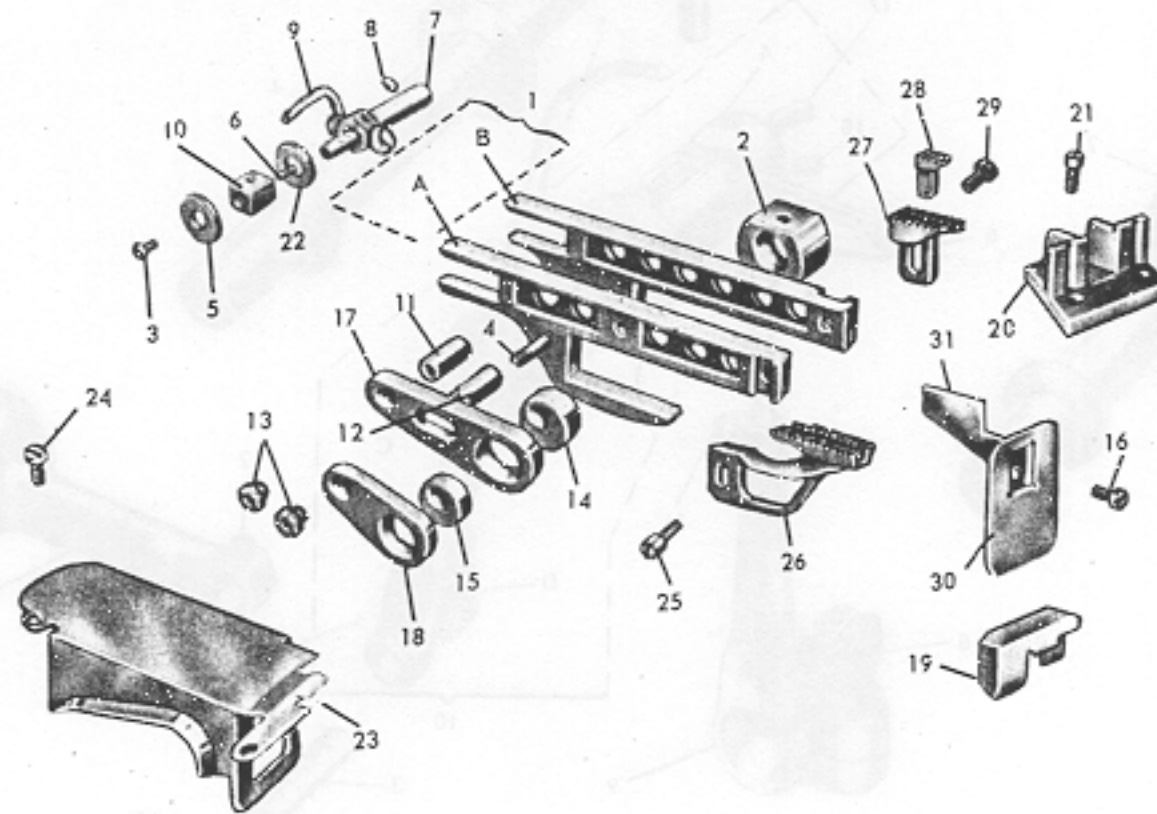

REF. N°	PART. N°	DESCRIPTION	QUANT.	REF. N°	PART. N°	DESCRIPTION	QUANT.
1	PM.280-049/1	slide differential	1	18	280-033/1	connector slide	1
2	280-611/1	block sliding	1	19	280-253	gasket	1
3	026-C-7	screw countersunk	1	20	270-640/3	guide block	1
4	280-023	bolt for feed dog holder	2	21	005-L-11	screw guide block fixing	1
5	270-935	washer	3	22	071-H-5	washer	2
6	092-B-1	wick	1	23	280-207/2	guard oil	1
7	270-039	eccentric shaft for differential	1	24	026-C-7	screw oil guard fixing	2
8	270-937/1	screw shaft fixing	1	25	270-978	screw differential feed dog fixing	1
9	092-D-11	wick	2	26	270-050	feed dog differential	1
10	270-036/1	block sliding	1	27	280-051	feed dog subsidiary	1
11	280-035	bushing joint	1	28	270-052	feed dog chaining	1
12	280-034	bushing joint	1	29	270-977	screw subsidiary feed dog fixing	1
13	280-926	nut slide	2	30	270-250/2	shield rubber	1
14	280-0451/10	eccentric for subsidiary feed dog	1	31	270-249/1	shield	1
15	280-0451/9	eccentric for differential feed dog	1	A	280-049/1	slide main feed dog	1
16	004-L-7	screw shield fixing	2	B	280-043/1	slide subsidiary feed dog	1
17	280-048/1	connector slide	1				
						On request: 280-0511	Tab. 38

From the library of: Diamond Needle Corp

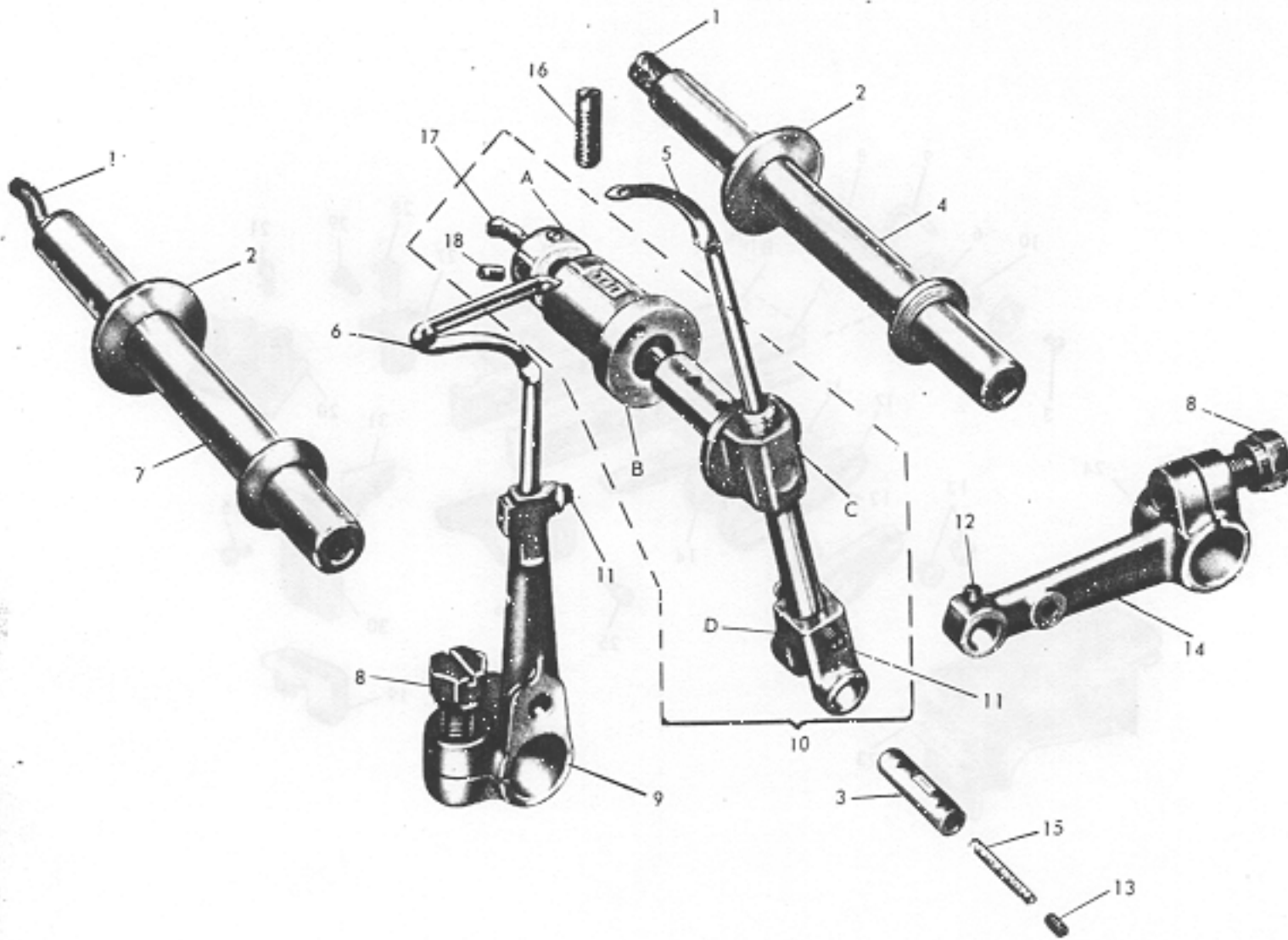

From the library of: Diamond Needle Corp

REF. N°	PART. N°	DESCRIPTION	QUANT.	REF. N°	PART. N°	DESCRIPTION	QUANT.
1	092-D-16	wick looper shaft	2	11	270-974/1	screw looper fixing	2
2	073-N-10	washer for looper shaft	2	12	016-B-4	fixing screw for upper looper gudgeon pin	1
3	270-070	gudgeon pin upper looper lever	1	13	016-B-2,5	grub screw gudgeon pin	1
4	270-064	shaft upper looper	1	14	270-067	lever upper looper	1
5	27277-074	upper looper with small eye	1	15	092-B-1	gudgeon pin wick	2
6	270-075/2	lower looper with small eye for cotton	1	16	017-F-11	screw bush fixing	1
7	270-069	shaft lower looper	2	17	092-D-7	wick	1
8	250-471	bolt looper lever	1	18	016-B-3	grub screw	2
9	270-068/3	holder lower looper	1	A	270-053	ring play adjustment	1
10	G.270-065/3	guide oscillating with screw bush	1	B	270-056/2	bush adjustable	1
				C	270-065/3	guide oscillating	1
				D	270-063/2	holder upper looper	1
On request: loopers shown in tab. 38							
27.277-0745							
270-D-074/1							
270-075							



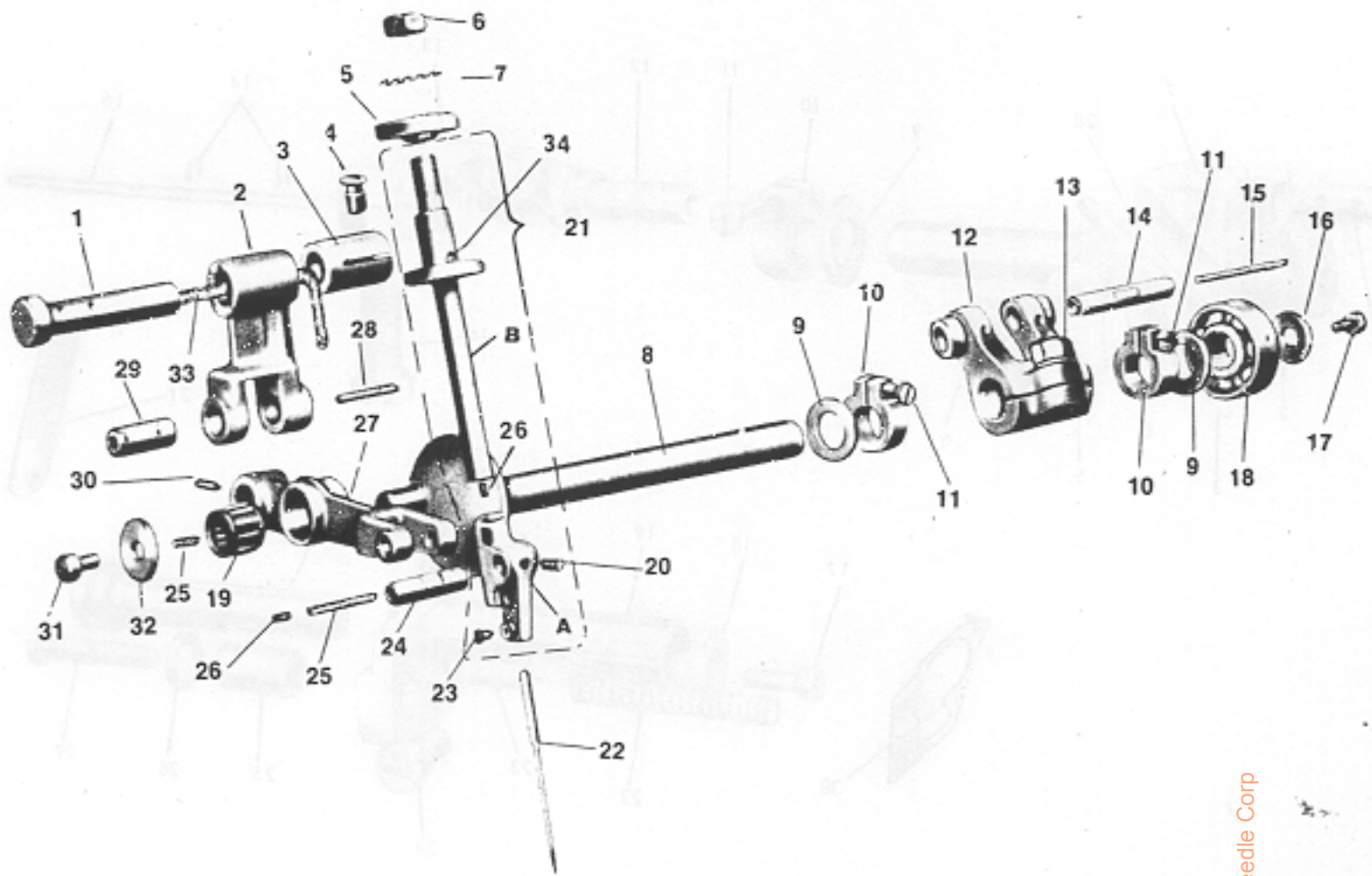

From the library of: Diamond Needle Corp

REF. N°	PART. N°	DESCRIPTION	QUANT.	REF. N°	PART. N°	DESCRIPTION	QUANT.
1	PM.270-138/1	shaft for fork lever	1	19	250-708/1	cage, roller bearing for needle drive lever	1
2	PM.270-137/1	fork lever	1	20	016-B-2,5	screw gudgeon pin fixing	1
3	270-132/1	bush for fork lever	1	21	G.270-025/2	assembly needle bar	1
4	270-728/1	screw bush fixing	1	22	RIM. 27	needle	1
5	290-027/1	ring for needle guide bar	1	A	270-020/1	clamp needle holder	1
6	270-933	nut for guide bar	1	B	290-025/1	needle bar	1
7	270-713	spring washer	1	23	003-A-4,5	screw retaining needle	1
8	270-006/1	shaft operating slide lever	1	24	270-130	gudgeon pin clamp	1
9	073-F-9	washer for upper shaft	2	25	092-B-1	wick gudgeon pin	2
10	270-719	collar for upper shaft	2	26	016-A-2,5	screw needle bar wick retaining	2
11	007-C-11	screw collar	2	27	270-135	bar slide drive	1
12	270-007/1	attachment shaft	1	28	092-D-5	wick gudgeon pin	1
13	270-975/1	attachment screw for 270-007/1	1	29	270-133/1	gudgeon pin fork lever	1
14	270-031/1	gudgeon pin for attachment	1	30	023-N-5,5	grub screw fixing needle bar drive lever	1
15	092-D-6	wick gudgeon pin	1	31	001-E-7	bolt upper shaft end	1
16	071-E-5	washer for upper shaft	1	32	270-131	washer shim	1
17	001-G-10	bolt washer holding	1	33	092-D-11	wick for shaft	1
18	270-708	bearing for upper shaft	1	34	092-A-10	wick	1

NO. 1000000000

From the library of: Diamond Needle Corp

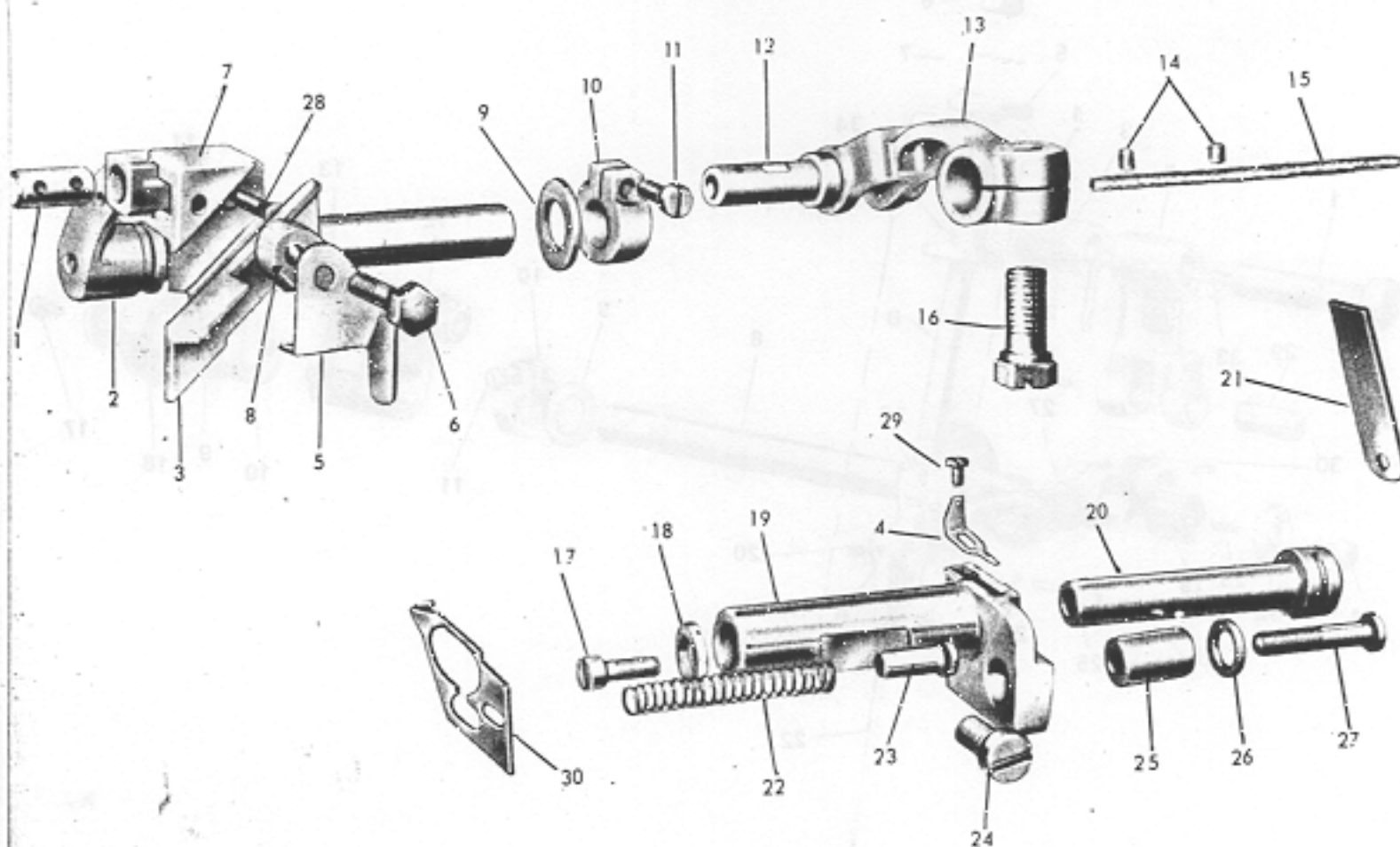

From the library of: Diamond Needle Corp

REF. N°	PART. N°	DESCRIPTION	QUANT.	REF. N°	PART. N°	DESCRIPTION	QUANT.
1	270-102	pin for upper knife holder	1	16	250-471	bolt for upper knife driving lever	1
2	270-096/1	holder upper knife	1	17	007-P-10	screw lower knife fixing	1
3	270-112	knife upper serrated	1	18	071-D-5	washer lower knife shaft	1
4	2777-228	guard	1	19	270-104	holder lower knife	1
5	128-111	guard upper knife	1	20	270-105	shaft lower knife holder	1
6	270-987	bolt upper knife fixing	1	21	270-113/1	knife lower	1
7	270-099	block upper knife holding	1	22	270-100	spring lower knife	1
8	270-103	snug upper knife locking	1	23	270-106	pin for lower knife holder	1
9	073-F-9	washer for upper knife holder	1	24	003-L-12	bolt knife holder fixing	1
10	270-719	lock ring for upper knife holder	1	25	270-101	bush support guide	1
11	007-C-11	screw lock ring	1	26	070-F-4	washer bush	1
12	270-108/1	gudgeon pin for attaching fork	1	27	270-877	bolt for lower knife bush	1
13	270-098	coupling fork	1	28	028-B-5	bolt for upper knife holder	1
14	092-C-2	wicks gudgeon pin	2	29	004-A-5	screw guard fixing	1
15	092-D-9	wick knife holder	1	30	27.77-227	stop-plate rear needle guard	1
On request:							
270.112/2						Tab. 39	
270.113/2						" 39	

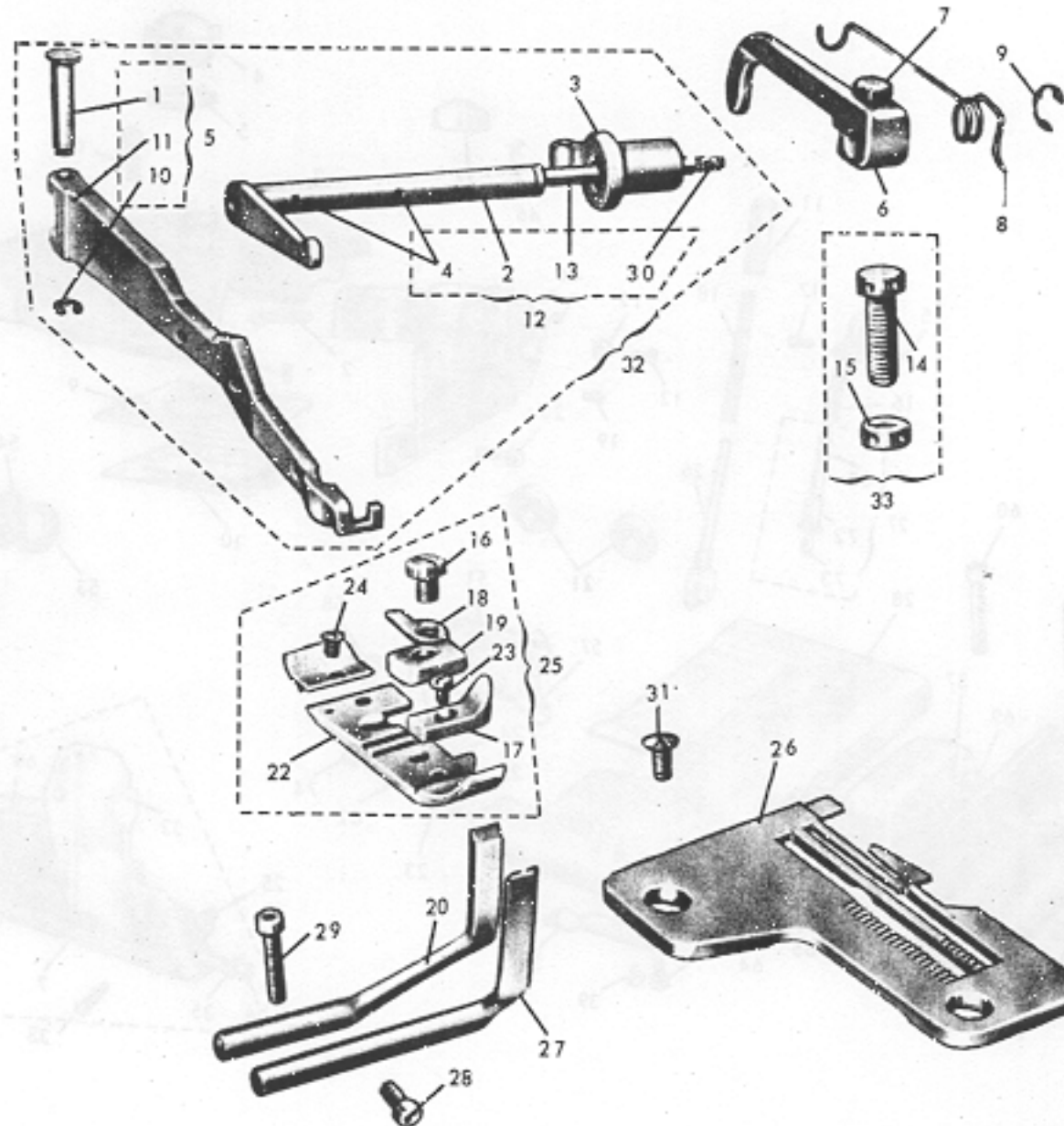

From the library of: Diamond Needle Corp

REF. N°	PART. N°	DESCRIPTION	QUANT.	REF. N°	PART. N°	DESCRIPTION	QUANT.
1	270-077	pin for presserfoot holder lever	1	18	270-196	locator	1
2	270-081/1	shaft of presserfoot raising lever	1	19	270-191	bracket presserfoot fixing	1
3	270-083	bush for raisable lever	1	20	270-109/1	rear needle guard	1
4	092-C-2	wick	4	21	270-184	shoe presserfoot	1
5	PM.270-076/2	assembly presserfoot holding lever	1	22	270-185	plate chain guide	1
6	270-087/1	lever presserfoot raising	1	23	270-989	screw block.	1
7	270-985	screw for presserfoot raising lever	1	24	0C1-A-3,2	screw plate	1
8	270-089/1	spring for presserfoot raising lever	1	25	G.270-181	assembly presserfoot	1
9	270-714	snap ring	1	26	270-1141	needle plate, fine seam	1
10	270-701	snap ring	1	27	270-107/1	front needle guard	1
11	270-076/2	lever, presserfoot holding. raisable	1	28	270-936/2	bolt fixing front needle guard	1
12	PM.270-081/1	shaft	1	29	270-934/2	bolt fixing rear needle guard	1
13	270-073	pipe	1	30	092-D-11	wick shaft	1
14	270-085/1	pin adjusting	1	31	032-L-10,5	screw fixing needle plate	2
15	270-091	nut	1	32	G.270-076/2	assembly raisable lever	1
16	004-L-7	bolt presserfoot tongue	1	33	PM.270-085/1	pin adjusting	1
17	270-183	block	1				
						On request:	
						PM.270-1882	Tab. 38
						G.274-401	38
						G.270-1812	38
						270-114	38
						270-1142	38
						270-1143	38
						270-188	39
						001-A-4,3	39
						270-401	38

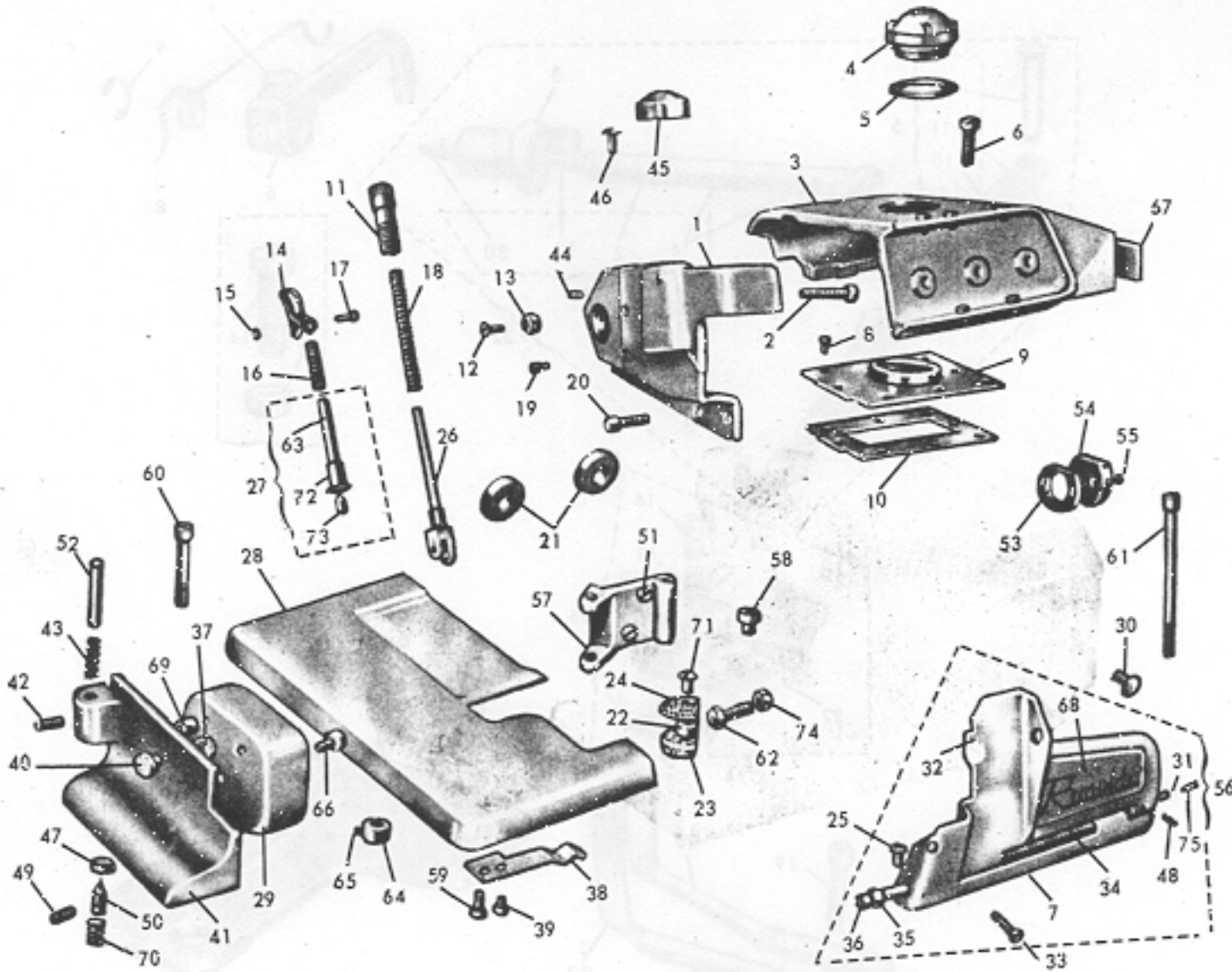

From the library of: Diamond Needle Corp

REF. N°	PART. N°	DESCRIPTION	QUANT.	REF. N°	PART. N°	DESCRIPTION	QUANT.
1	PM.270-208/3	side cover with bush	1	38	270-212	spring clip for closing	1
2	007-H-25	bolt for upper cover	1	39	001-D-6	screw spring clip fixing	1
3	PM.270-205/3	cover with bush	1	40	608-405	knob	1
4	270-241/2	cap oil filler	1	41	280-209/1	cover side	1
5	270-965/2	gasket for oil filler cap	1	42	016-B-4	grub screw	1
6	270-983	screw cover fixing	1	43	280-236	spring	1
7	PM.270-218/2	hinge	1	44	270-715	grub screw locking knob 270-093/1	1
8	007-R-7.5	screw for fixing plate	7	45	270-129/1	cover shaft	1
9	G.270-245/4	plate with bush	1	46	270-731/1	screw for attachment W1	2
10	270-246	gasket plate	1	47	280-921	pad	1
11	270-093/1	knob spring regulating	1	48	270-913	pin for front cover plate	1
12	032-F-9.5	screw for eccentric washer	1	49	016-D-6	screw pin	1
13	605-412	washer	1	50	280-226/1	pin	1
14	270-094	lever presserfoot release	1	51	001-G-12	screw kinge	2
15	270-701	washer spring	1	52	280-225	pin	1
16	270-086	spring tie bar	1	53	270-624	gasket cover disc	1
17	270-078	pin for presserfoot release lever	1	54	270-623/1	disc cover	1
18	270-092	spring presserfoot pressure	1	55	001-D-10	screw cover disc	2
19	270-993	screw stop	1	56	G.270-216/2	assembly front cover plate	1
20	270-995	screw fixing upper cover	2	57	280-203/2	hinge	1
21	270-066/2	caps, rear, for bushes	2	58	280-303	nipple fixing cover	1
22	633-925	spacer	1	59	001-D-4,5	screw spring clip fixing	1
23	280-945	disc felt	1	60	270-973	bolt short	1
24	280-244/1	filter oil	1	61	270-972	bolt long	1
25	01205/A	screw	3	62	270-214	screw fixing work plate	1
26	PM.270-095/3	shaft presserfoot alignment	1	63	270-110	tie bar	1
27	G.270-090/1	shaft presserfoot release	1	64	270-718	ring for fixing work plate	1
28	PM.270-210/3	plate work	1	65	017-E-4,5	screw for work plate fixing ring	2
29	280-214/1	cover	1	66	004-L-9	screw cover fixing	3
30	270-730/2	plug for blocking hole	2	67	270-174	nameplate for tension holder cover	1
31	270-220/1	pin for front cover plate	1	68	270-175	nameplate on front cover plate	1
32	PM.270-217/2	cover plate with fin	1	69	280-215	spacer	3
33	007-F-14	screw cover plate	1	70	602-E-4434	spring pin	1
34	270-221	spring for front cover plate	1	71	001-E-12	screw fixing filter	1
35	054-D-4	nut for lock screw	1	72	270-090/1	block tie bar	1
36	270-226	lock screw	1	73	290-923	grub screw tie bar	1
37	053-D-4	lock nut knob	1	74	057-E-4	nut for work plate fixing screw	1
				75	016-E-5,5	screw for front cover plate	1

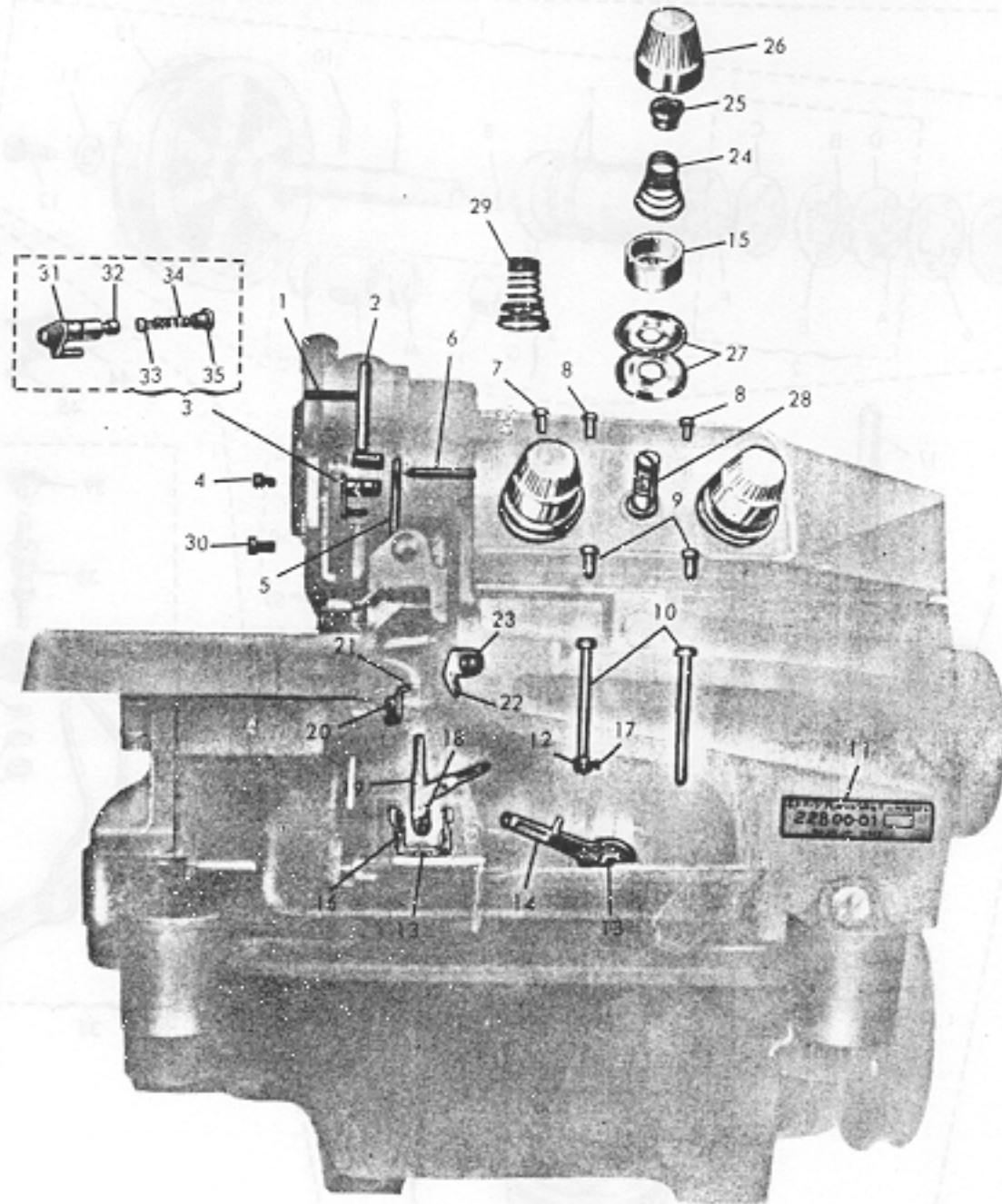

From the library of: Diamond Needle Corp

REF. N°	PART. N°	DESCRIPTION	QUANT.	REF. N°	PART. N°	DESCRIPTION	QUANT.
1	270-941	screw fixing needle thread, thread-guide	1	19	270-270/1	tensioner upper looper thread	1
2	PM.270-263/1	thread guide for needle thread	1	20	004-A-3,2	screw fixing guard	1
3	G.270-262/2	thread clasp complete	1	21	270-276/1	guard looper stop	1
4	004-A-5	screw fixing needle tensioner	1	22	270-275/1	guide upper looper thread	1
5	270-274/3	thread tensioner for needle thread	1	23	032-A-6	screw fixing thread guide	1
6	270-264	thread guide needle	1	24	272-232/1	spring looper	2
7	270-265	bush upper thread guide	1	25	270-233	bush upper tension	3
8	270-265/1	bush upper thread guide	2	26	270-235/1	knob, threaded, for tensioning	3
9	270-266	bush lower thread guide	2	27	603-031	disc tension	6
10	270-268	tube lower thread guide	2	28	270-230	pin, threaded, for tensioning	3
11	781001-0-00	nameplate showing machine class	1	29	270-232/2	spring needle	1
12	270-271	thread guide for lower looper thread	2	30	004-N-5,5	screw fixing thread tensioner	2
13	036-C-7	screw for looper thread tensioner	2	31	PM.270-262/2	body with pin	1
14	270-272	thread tensioner for lower looper thread	1	32	270-255	pin thread clasp	1
15	270-234/1	cap tensioner retainer	3	33	270-259	pin tube	1
16	270-269/1	tensioner lower looper thread	1	34	270-258	spring thread take-up	1
17	016-B-2,5	screw fixing thread guide	1	35	270-261/1	cap thread take-up	1
18	004-L-6	screw fixing thread tensioner	1				

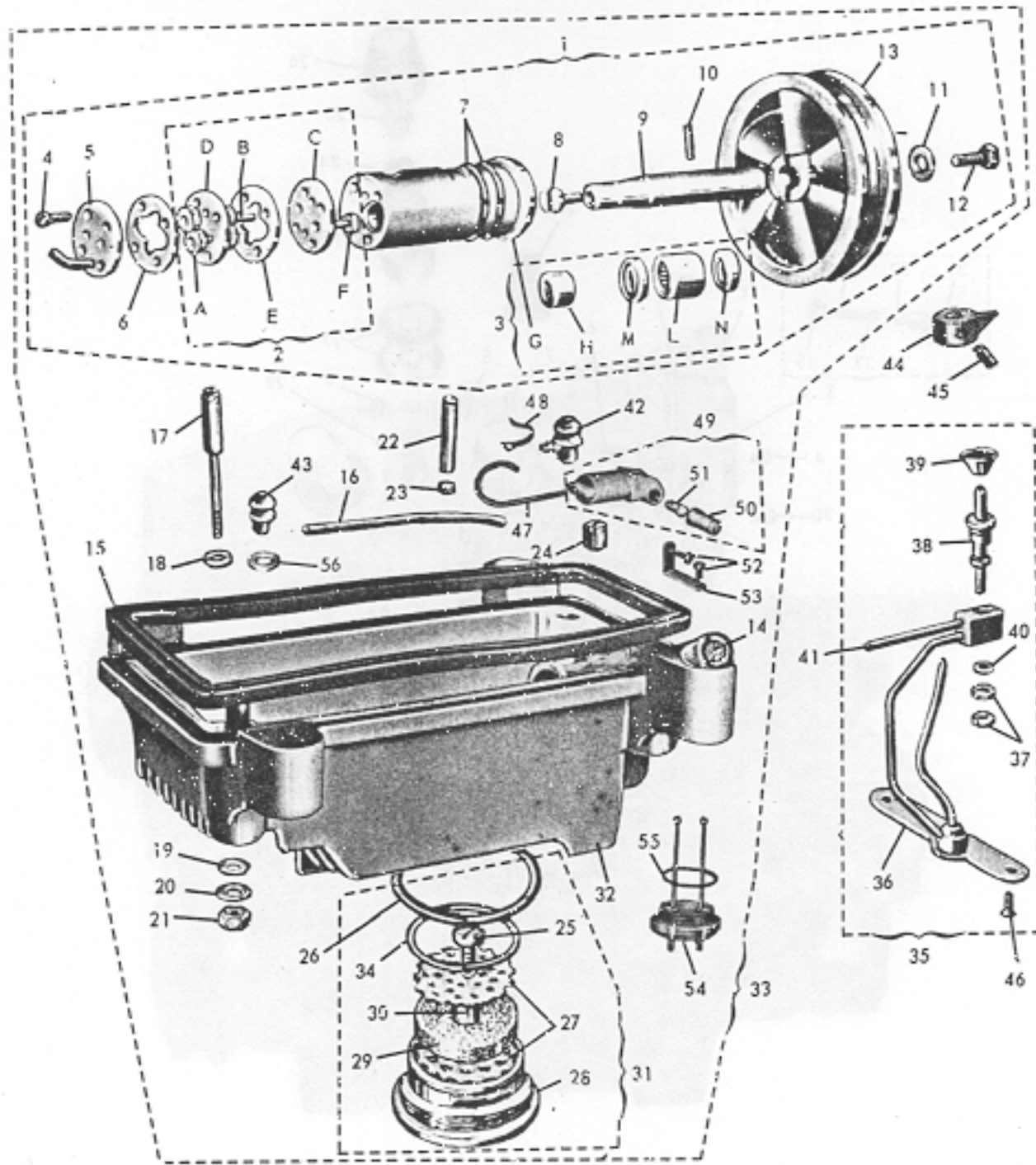

From the library of: Diamond Needle Corp

REF. N°	PART. N°	DESCRIPTION	QUANT.	REF. N°	PART. N°	DESCRIPTION	QUANT.
1	G.270-816/1	assembly oil pump	1	34	270-966/1	gasket	1
2	G.633-833/1	assembly gear	1	35	G.270-646	assembly oil distributor	1
3	PM.270-816/1	body pump	1	36	PM.270-646/1	distributor	1
4	633-812	screw	1	37	057-A-3	nut	2
5	PM.633-817/1	cover	1	38	270-650	valve deviator	1
6	633-816/1	washer	1	39	270-651	gasket	1
7	633-711/1	gaskets	2	40	270-734/1	washer spring	1
8	270-824/1	screw drag	1	41	270-652	pipe connecting	1
9	270-823/1	shaft	1	42	270-8251	pipe oil pump union	1
10	533-708	pin spring	1	43	633-826/1	pipe oil pump union	1
11	633-707	washer spring	1	44	270-645	pointer for oil distributor	1
12	039-G-10	bolt fixing pulley	1	45	016-B-2,5	grub screw pointer	1
13	270-810/2	pulley oil pump	1	46	028-E-10	screw	2
14	633-959/1	spy glass oil	1	47	270-434	pipe from pressure switch	1
15	270-808	gasket	1	48	270-W1-328	clamp pipe	1
16	633-842	pipe	1	49	AS.270-410	pressure switch assembly	1
17	270-811/1	pin	2	50	270-4281	cover	1
18	270-946	gasket	2	51	270-422/1	bulb 15 V. 3 W.	1
19	270-947	gasket	2	52	001-E-7	screw fixing pressure switch	2
20	065-L-6	washer	2	53	270-435	bracket support	1
21	059-G-6	nut	2	54	270-432	plug with current pick-ups	1
22	270-831/1	pipe	1	55	270-430	gasket rubber	1
23	270-836	pad felt	1	A	633-821/2	gear	4
24	017-H-12	grub screw	1	B	633-822/2	pin gear	1
25	007-L-20	screw	1	C	633-819	plate side	1
26	633-966	gasket	1	D	633-833	plate internal	1
27	270-828/1	grating	1	E	633-818/1	washer internal	1
28	270-996/2	plug	1	F	633-834/1	pin drag	1
29	270-827/1	pad felt	1	G	270-816/1	body pump	1
30	633-925	spacer	1	H	633-814	sheath roller bearing	1
31	G.270-996/2	plug sump	1	L	633-813	sheath roller bearing	1
32	270-001/2	sump	1	M	670-702	ring sealing	2
33	G.270-001/2	assembly sump	1	56	280-946	spacer for connecting pipe	1

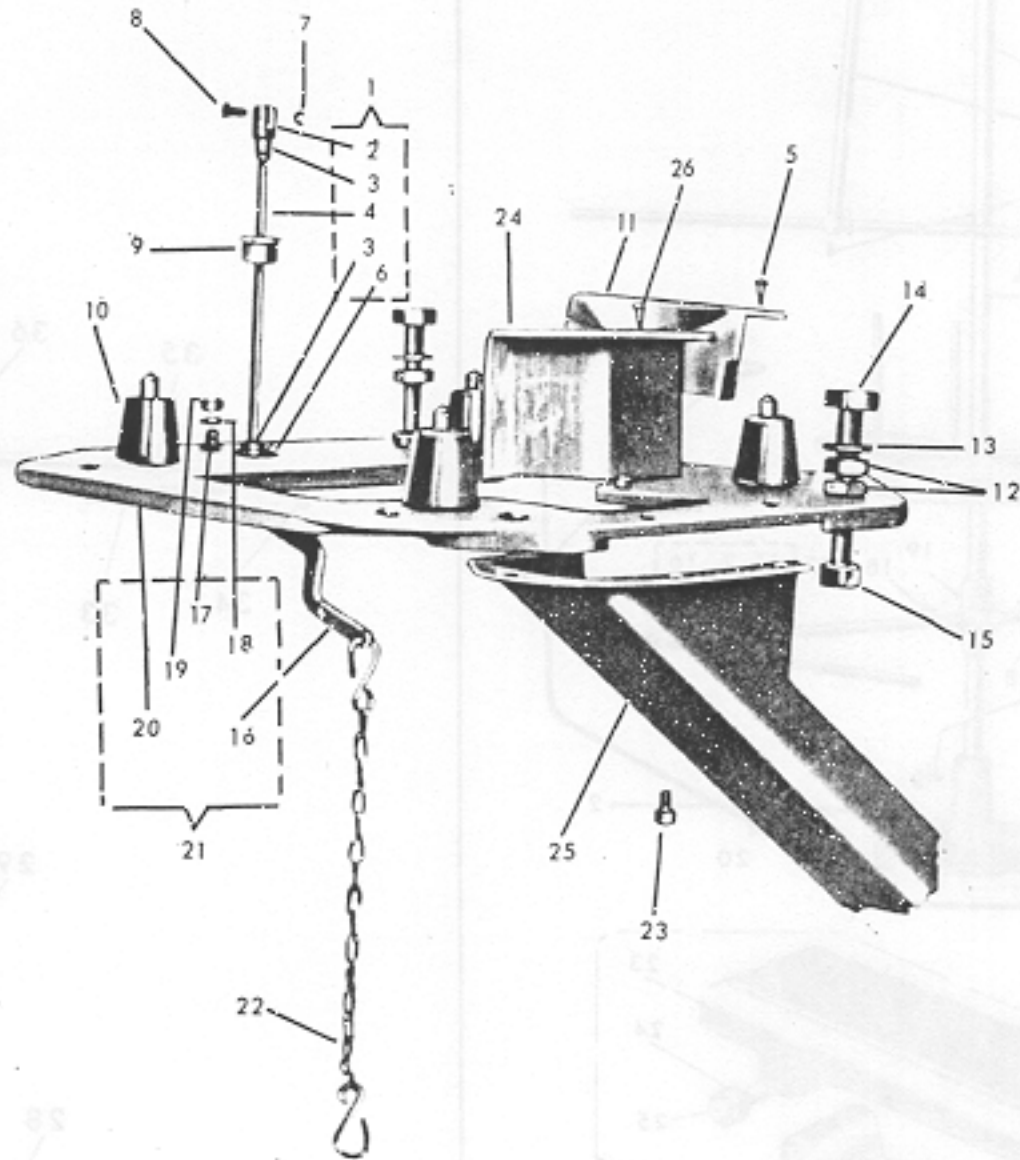

From the library of: Diamond Needle Corp

REF. N°	PART. N°	DESCRIPTION	QUANT.	REF. N°	PART. N°	DESCRIPTION	QUANT.
1	G.270-583	assembly tie bar	1	12	058-M-10	nut for bolts holding machine	8
2	270-585	joint, upper, for presserfoot raising lever	1	13	067-H-10	washer for plate supporting machine	4
3	059-A-5	nut for the bar	2	14	270-971	bolt for plate supporting machine	4
4	270-583	rod for presserfoot raising lever	1	15	051-L-10	nut for fixing plate to table	4
5	270-459	rivet fixing	7	16	270-586/1	lever controlling presserfoot lifter	1
6	270-557	joint for presserfoot raising lever	1	17	270-584	support for lever	1
7	270-701	ring snap	2	18	065-L-6	washer pin	1
8	270-558	pin for joint	2	19	059-H-6	nut for support	1
9	270-552	bush, upper, for table	1	20	PM.270-005/3	plate with pins	1
10	270-004	shock absorber for machine	4	21	G.270-005/3	plate machine support	1
11	270-588	guard pulley wheel	1	22	PM.1159	chain with hook	1
				23	001-G-10	On request: screw channel fixing	3
				24	270-589/1	mouth waste chute	1
				25	270-590/1	waste chute to the right	1
					270-590/2	waste chute to the left	1
				26	270-459	rivets fixing	9



12

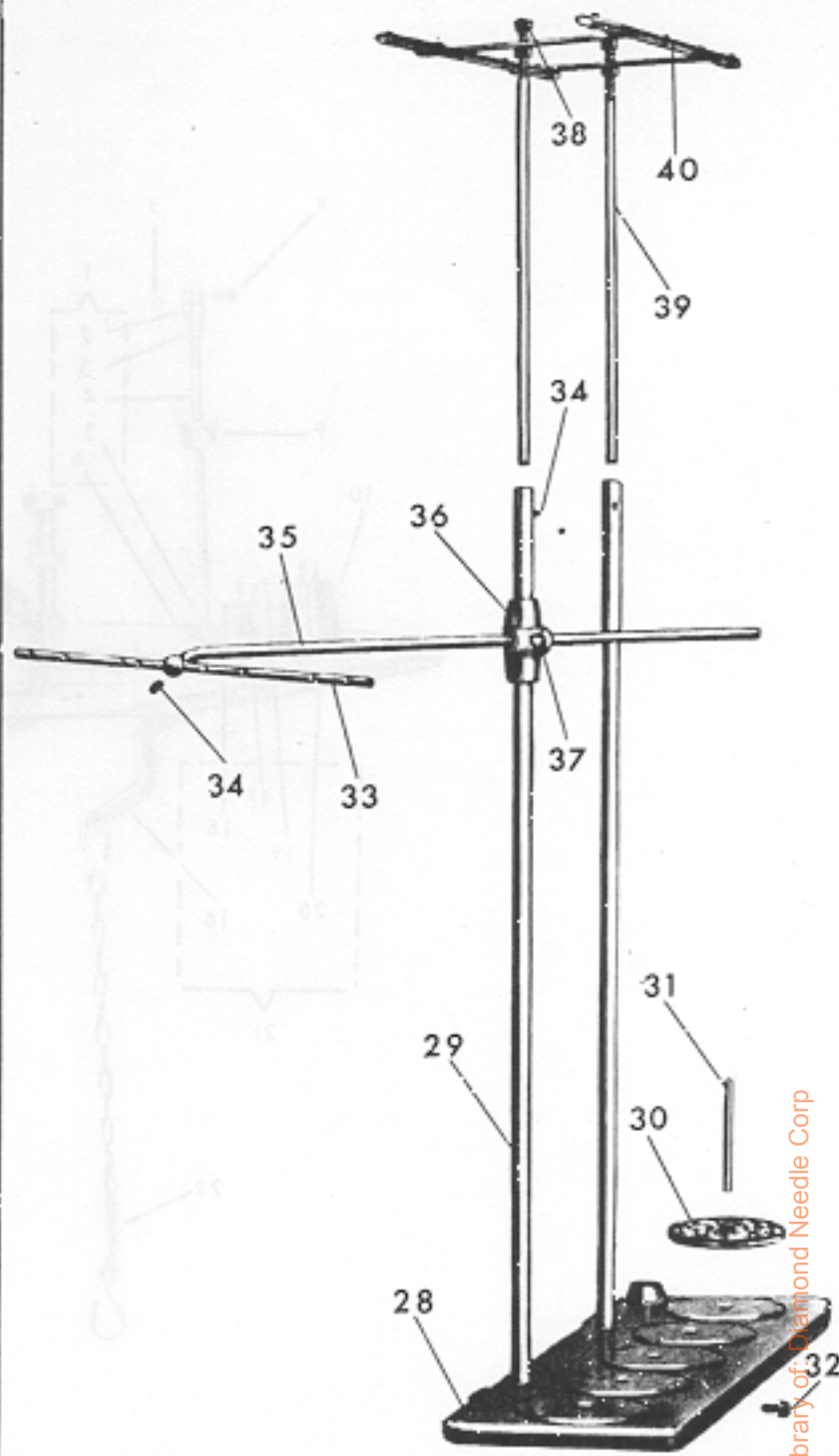
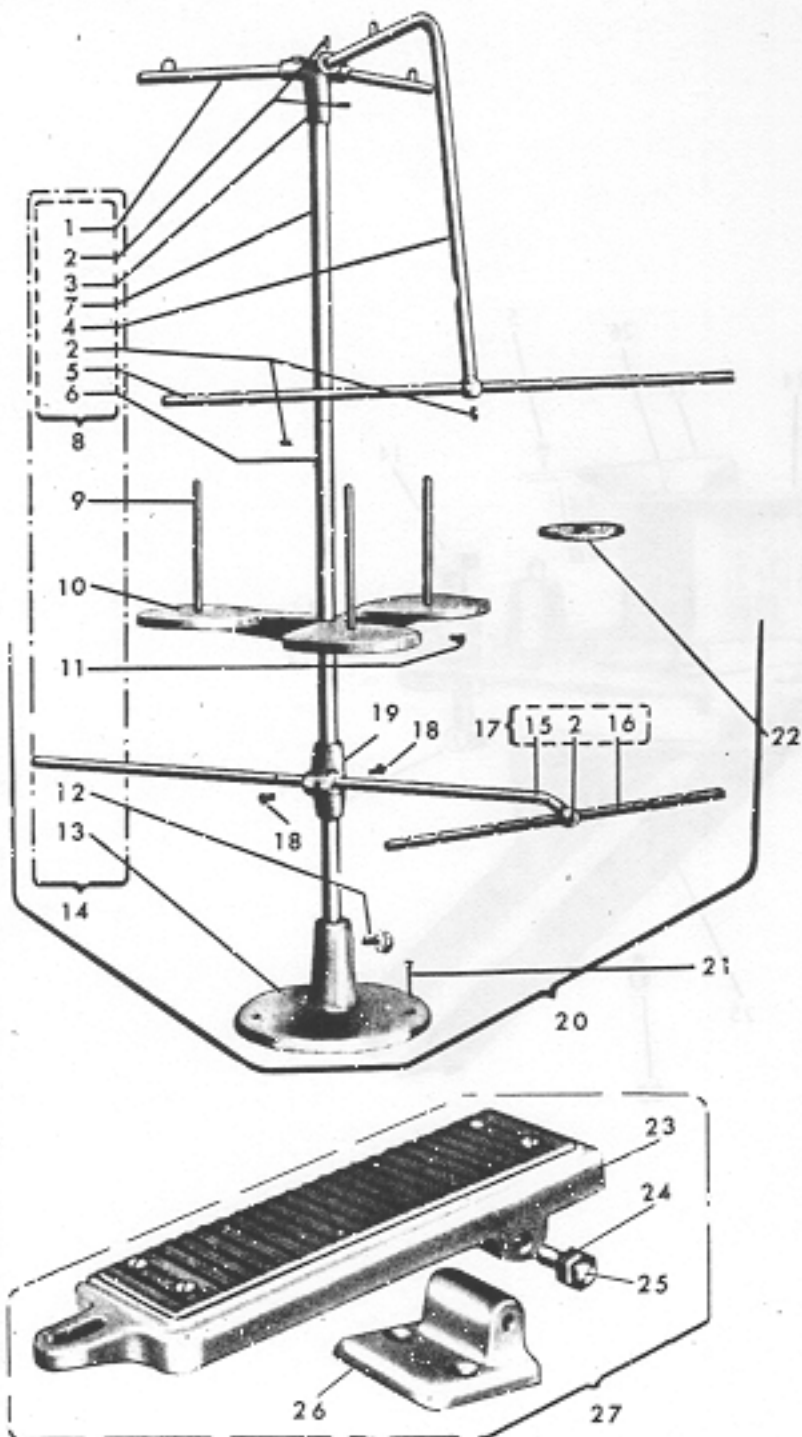

From the library of Diamond Needle Corp

REF. N°	PART. N°	DESCRIPTION	QUANT.	REF. N°	PART. N°	DESCRIPTION	QUANT.
SUPPLIED WITH HEAD ONLY				SUPPLIED WITH BENCH			
1	PM.250-133/1	rod thread guide	2	28	490/2	holder reel	1
2	016-F-6,5	grub screw	8	29	910-143	rod main support	2
3	250-140	union rod	1	30	569	disc reel support	5
4	PM.250-148/1	support rod	1	31	1146	pin reel	5
5	250-137	rod thread guide	1	32	001-G-10	screws cheesehead	5
6	250-143	rod lower main	1	33	270-157	rod thread guide	1
7	250-130	rod upper main	1	34	016-F-5	grub screw	1
8	G.250-137	frame thread guide	1	35	270-158/1	support thread guide	1
9	1146	pin reel	3	36	605-937	support for reel pin	1
10	01142	plate reel base	1	37	605-980	knob knurled	2
11	001-G-10	screw fixing plate	1	38	1145	frame nut fixing	4
12	001-G-12	screw fixing rod	1	39	910-144	rod, upper, of frame	2
13	01141	base thread guide	1	40	G.497	frame thread guide	1
14	AS.250-149	assembly thread guide frame	1				
15	270-158/1	support rod	1				
16	270-157	rod thread guide	1				
17	G.270-157	support with thread guide rod	1				
18	605-980	grub screw	3				
19	605-937	support	1				
20	AS.270-140	assembly complete thread guide frame	1				
21	TS.20 x 30	screw for fixing frame	2				
22	569	disc spool support	3				
23	PM.910-914	pedal	1				
24	053-H-8	nut pedal	2				
25	910-964	bolt pointed	2				
26	910-934/1	support pedal	1				
27	G.910-914/1	assembly pedal	1				

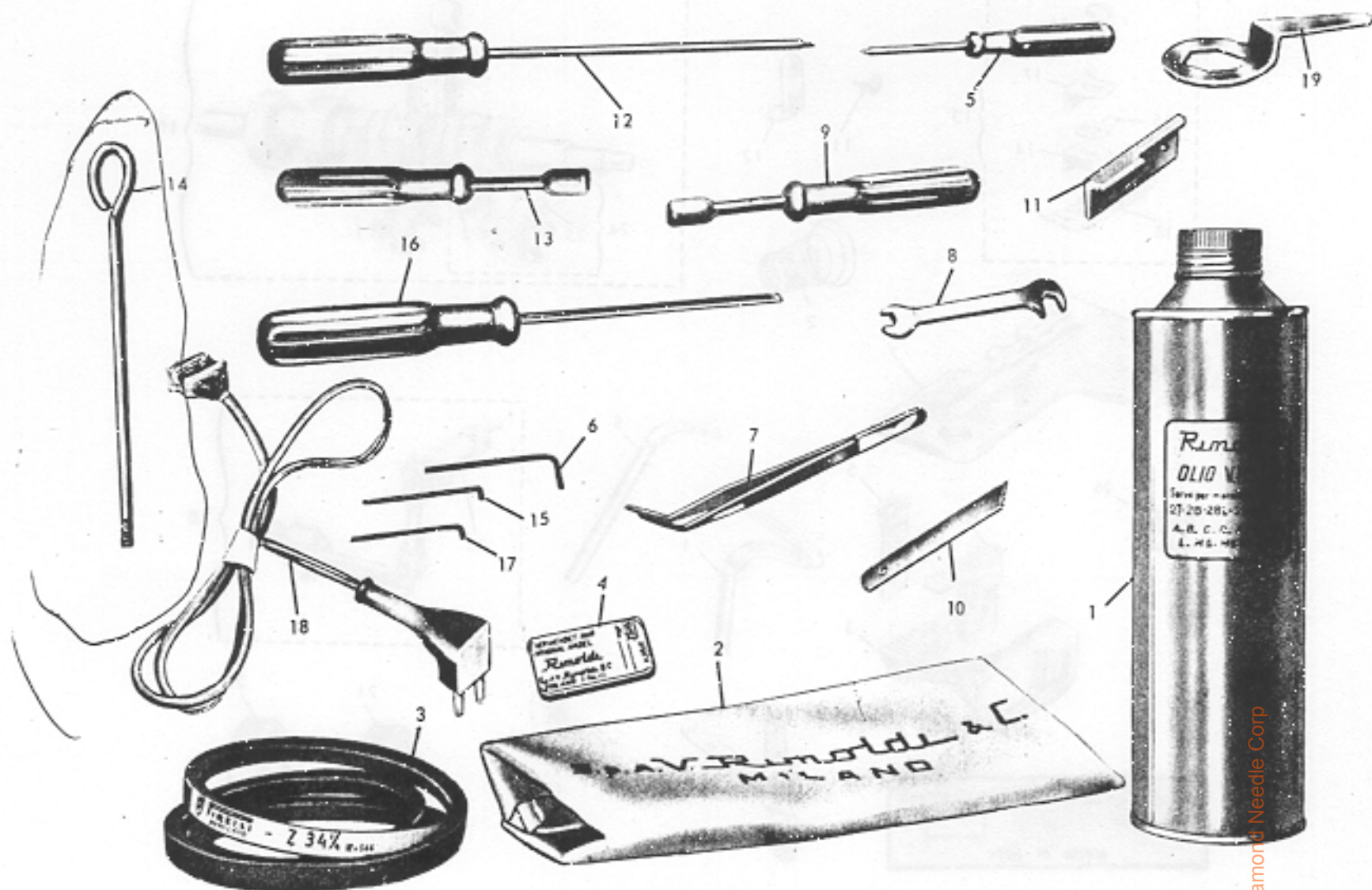

13

From the library of: Diamond Needle Corp

REF. N°	PART. N°	DESCRIPTION	QUANT.	REF. N°	PART. N°	DESCRIPTION	QUANT.
1	VR. 604	oil 1 Kg.	1	11	270-112	knife upper	1
2	1175	dust cover for machine	1	12	01160/2	screwdriver	1
3	280-155	vee belt	1	13	280-742	socket spanner 23/64"	1
4	HIM. 27	needle	5	14	280-745	extractor eccentric	1
5	1161/2	screwdriver	1	15	270-743	allen key 5/64"	1
6	633-742	allen key 1/8" for 270-715	1	16	01161/2	screwdriver	1
7	1158	tweezers for threading	1	17	641-LY-743	allen key 3/32"	1
8	1156/1	spanner double ended 7 . 9	1	18	270-431	lead mains	1
9	270-741	socket spanner 9/32"	1	19	639M-745	spanner sump plug	1
10	270-113/1	knife lower	1				
						On request 270-675/1 Tab. 38	

47

14

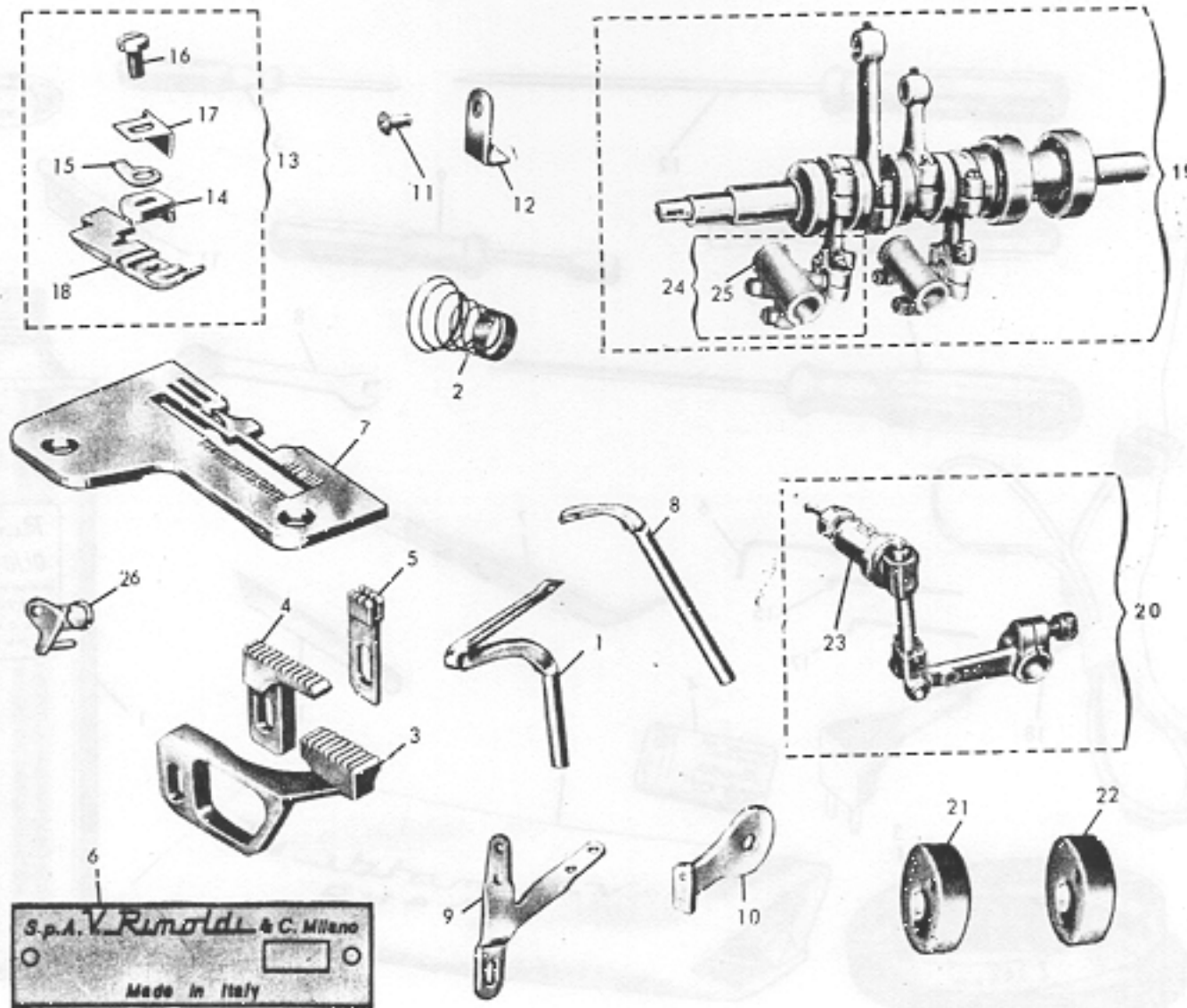

From the library of: Diamond Needle Corp

REF. N°	PART. N°	DESCRIPTION	QUANT.	REF. N°	PART. N°	DESCRIPTION	QUANT.
1	270-0751	looper lower	1	14	272-B-191	tongue	1
2	270-232/1	spring lower looper tension	1	15	270-196	locator	1
3	272-B-050	feed dog main	1	16	004-L-8	screw	1
4	282-B-051	feed dog subsidiary	1	17	27 B-183	plate	1
5	272-B-052	feed dog chaining	1	18	272-B-184/1	slide	1
6	781002-0-00	name plate showing machine class	1	19	G.28.21-C2-009/4	main shaft assembly	1
7	272-B-1141	needle plate bight width 9/64"	1	20	G.27.21-C2-067/3	looper drive shaft with connecting rods	1
8	270-074	looper upper	1	21	280-0461/16	eccentric for main feed dog	1
9	272-B-270	tensioner upper looper thread	1	22	280-0451/12	eccentric for subsidiary feed dog	1
10	272-B-272	tensioner lower looper thread	1	23	27.21-C2-056	bush eccentric for upper looper drive	1
11	27.01-P-403/1	screw fixing guard lever	1	24	PM.27.21-C2-059	con-rod with coupling	1
12	272-186	guard presserfoot stop	1	25	27.21-C2-059	coupling	1
13	G.272-B2-181	assembly presserfoot	1	26	G.270-262/3	thread take-up needle thread	1
					272-B-0501	see Tab. 38	
					282-B-0511	see Tab. 38	
					272-B-114	see Tab. 38	
					272-092	see Tab. 38	

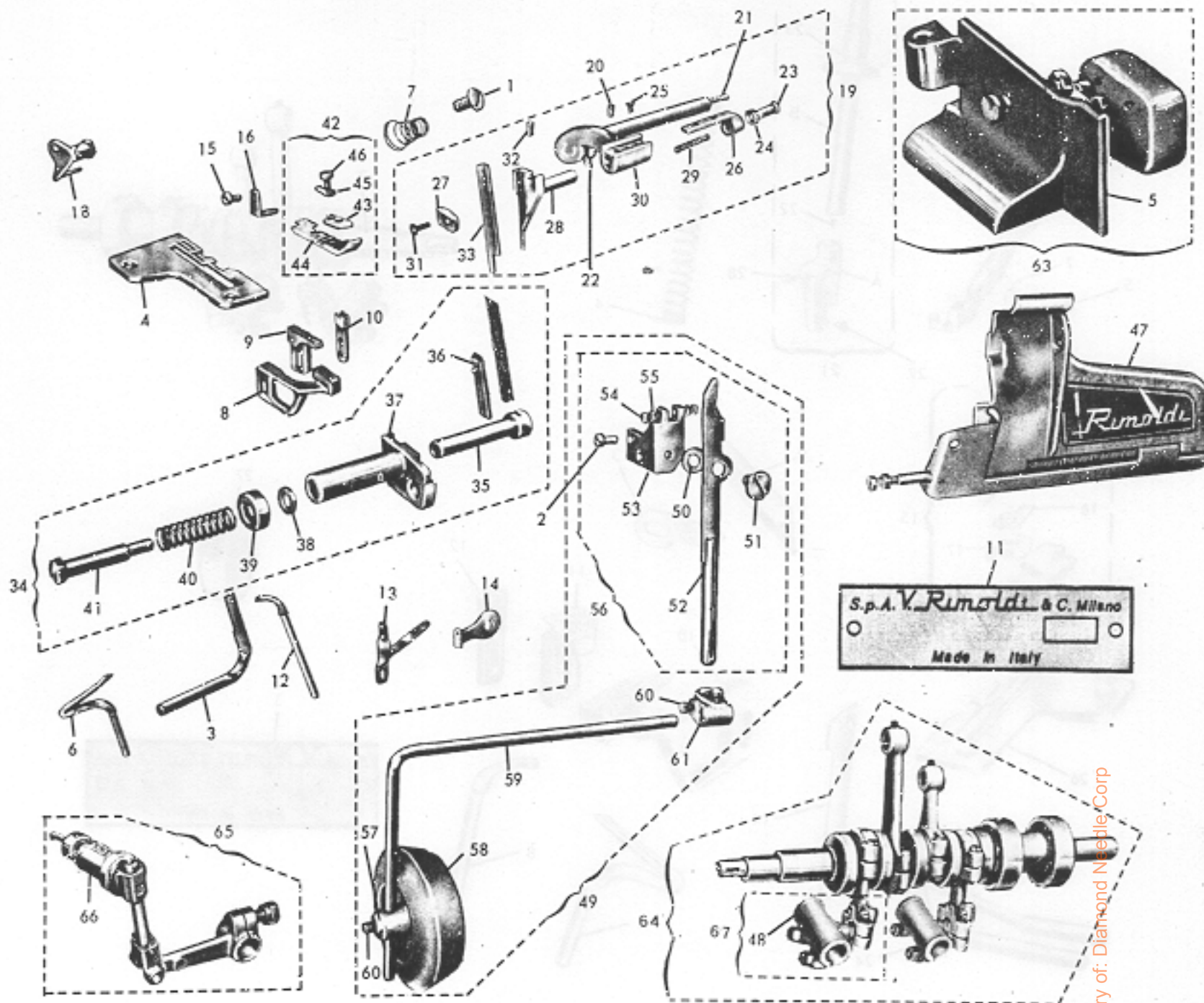

From the library of: Diamond Needle Corp

REF. N°	PART. N°	DESCRIPTION	QUANT.	REF. N°	PART. N°	DESCRIPTION	QUANT.
1	003-M-7	screw	1	35	272-BK-1051	shaft	1
2	026-G-10	screw lever lock	1	36	PM.272-BK-110	plate	1
3	272-BK-107	front needle guard	1	37	272-BK-104	holder knife	1
4	272-BK-114	needle plate bight tongue 1/16"	1	38	071-D-5	washer	1
5	282-BK-209	side cover	1	39	272-BK-994	retainer spring	1
6	270-0751	looper lower	1	40	272-BK-976	spring	1
7	270-232/1	spring lower looper tension	1	41	272-BK-986	bolt	1
8	272-B-050	feed dog main	1	42	G.272-BK-181	assembly presserfoot	1
9	282-B-051	feed dog subsidiary	1	43	272-BK-191	bracket	1
10	272-B-052	feed dog chaining	1	44	272-BK-184	slide	1
11	781003-0-00	name plate showing machine class	1	45	270-196	locator	1
12	270-074	looper upper	1	46	004-L-7	screw	1
13	272-B-270	tensioner upper looper thread	1	47	G.272-BK-216/2	assembly front cover plate	1
14	272-B-272	tensioner lower looper thread	1	48	27.21-C2-059	coupling	1
15	27.01-P-403/1	screw guide block fixing	1	49	AS.272-BK-903	knee control, complete	1
16	272-186	guard presserfoot stop	1	50	272-BK-907	washer	1
17	280-0451/12	eccentric for subsidiary feed dog	1	51	272-BK-906	screw	1
18	G.270-262/3	thread take-up complete	1	52	PM.272-BK-903	lever	1
19	G.272-BK-096	holder, upper knife, complete	1	53	272-BK-905	support	1
20	092-C-2	wick	2	54	390-974	screw	2
21	092-D-11	wick	1	55	057-E-4	nut	2
22	092-D-2	wick	1	56	G.272-BK-903	lever for moving knife	1
23	272-BK-991	screw register	1	57	270-574	disc	1
24	059-A-5	nut	1	58	270-582	pad	1
25	004-A-3,2	screw	2	59	272-BK-573	rod	1
26	272-BK-102	guide	1	60	038-M-9	screw	3
27	272-BK-103	locator	1	61	270-572	attachment	1
28	272-BK-099	holder knife	1	62	280-0461/16	eccentric for feed dog	1
29	272-BK-100	spring	1	63	G.282-BK-209/1	cover, side protection	1
30	PM.272-BK-096	lever	1	64	G.28.21-C2-009/4	main shaft assembly	1
31	272-BK-987	screw	1	65	G.27.21-C2-067/3	looper drive shaft with connecting rods	1
32	255-442	pin	1	66	27.21-C2,056	bush eccentric	1
33	272-BK-112	knife	1	67	PM.27.21-C2-059	con-rod with coupling	1
34	G.272-BK-104	holder, knife, complete	1				
					On request:		
					272-BK-114/1	see Tab. 38	
					272-BK-1141	see Tab. 38	
					272-BK-675	see Tab. 38	

I. HEAD IDENTIFICATION

a) Identification numbers

1. Every head is identified by:
  - class and sub-class numbers
  - serial number
2. The class and sub-class numbers are engraved on the nameplate on the base of the machine.
3. The head serial number is engraved on a boss on the bottom of the base.

II. TECHNICAL DATA OF CLASS

The heads illustrated in this catalogue are of the single needle overedging type having the following general specifications:

1. Straight needle system RiM 27 - size from 55 to 100
2. Stitch length variable from 6 to 40 stitches per inch
3. Differential ratio up to 3,5 to 1
4. Width of bight from 3/64" - 15/64"
5. Speed from 6,000 to 7,000 r.p.m. according to performance
6. Lubrication by double stage pump
7. Motor: 1/3 HP or 1/2 HP according to sub-class
8. Overall head dimensions 300x240 mm.
9. Weight: about 43 lbs.

From the library of: Diamond Needle Corp

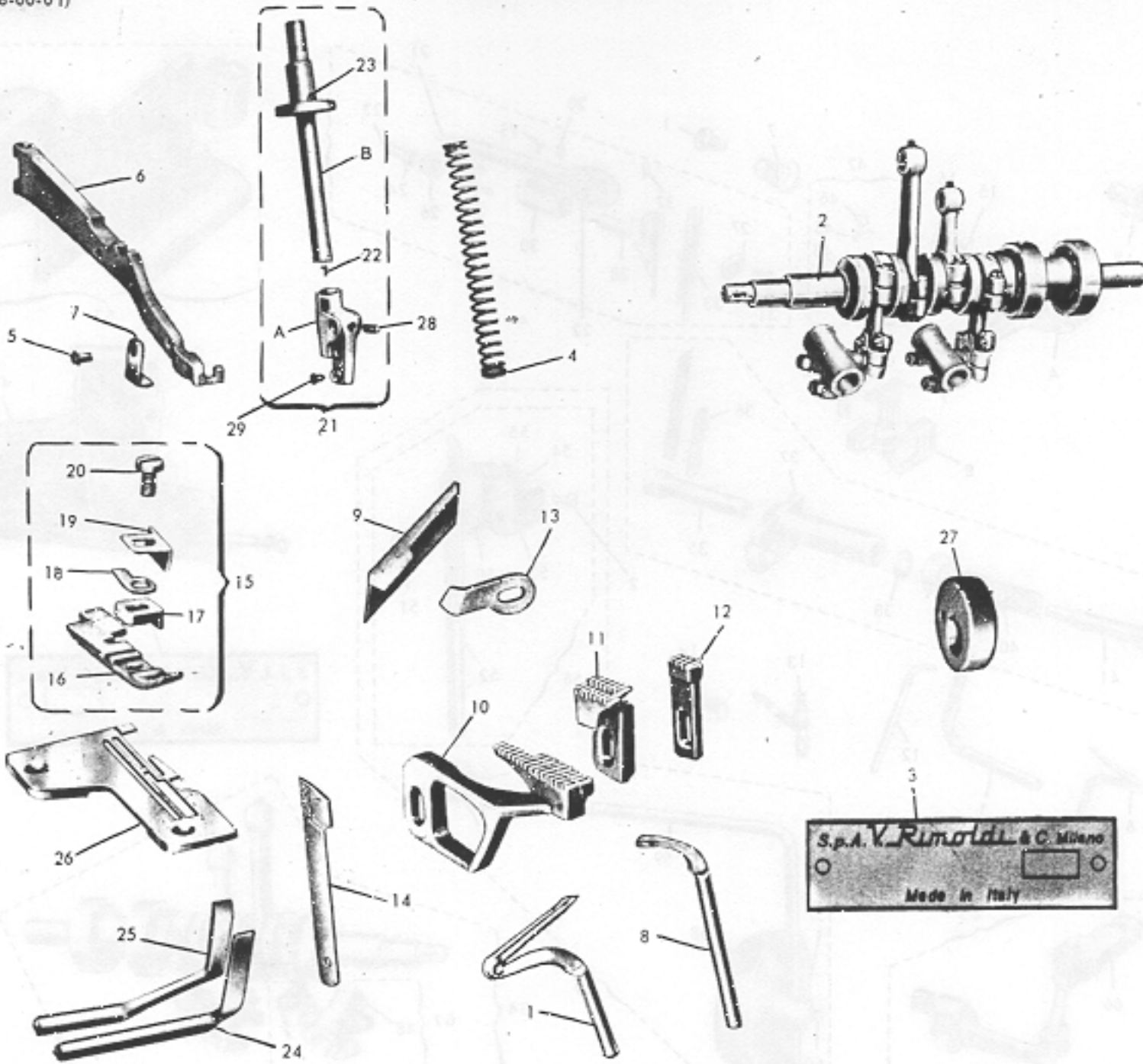

From the library of: Diamond Needle Corp

N° RIF.	N° DISEGNO	DENOMINAZIONE	QUANT.	N° RIF.	N° DISEGNO	DENOMINAZIONE	QUANT.
1	270-075	looper	1	16	277-184	slide	1
2	G.28.00-B-009/3	main shaft complete	1	17	277-191	tongue	1
3	781004-0-00	name plate showing machine class	1	18	270-196	locator	1
4	27.01-P-092	spring presserfoot pressure	1	19	277-183	plate	1
5	27.01-P-403/1	screw for bracket	1	20	004-L-8	screw	1
6	28.778-076/1	lever presserfoot holding raisable	1	21	G.27.77-025/2	needle bar with clamp	1
7	27.26-186	guard presserfoot stop	1	22	016-A-2,5	grub screw	1
8	27.277-0745	looper upper	1	23	092-A-10	wick	1
9	276-8-112	knife upper	1	24	27.77-107/1	front needle guard	1
10	277-0501	feed dog main	1	25	27.77-109/1	rear needle guard	1
11	28.00-87-051	feed dog subsidiary	1	26	27.77-1141	needle plate bight width 13/64"	1
12	277-052	feed dog chaining	1	27	280-0451/5	eccentric for main feed dog	1
13	128-110	guard upper knife holder	1	28	016-B-2,5	screw gudgeon pin fixing	1
14	277-113	knife lower	1	29	003-A-4,5	screw for needle clamp	1
15	G.277-181	assembly presserfoot	1	A	27.77-020	clamp	1
16				B	290-025/1	shaft	1
						On request:	
					270-075/2	see Tab. 38	
					27.277-074	see Tab. 38	
					28.00-87-0511	see Tab. 38	
					27.77-1142	see Tab. 38	

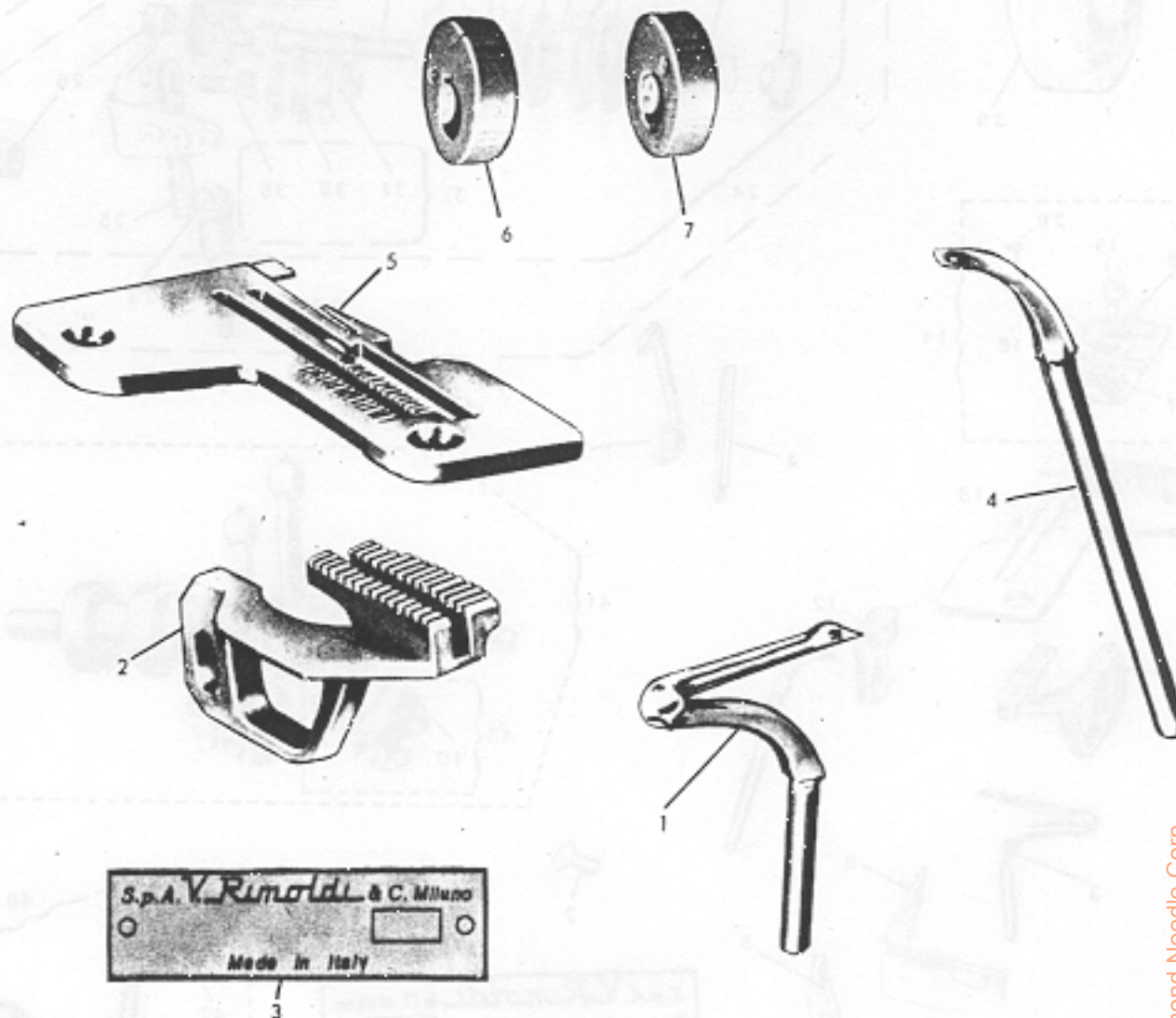

REF. N°	PART. N°	DESCRIPTION	QUANT.	REF. N°	PART. N°	DESCRIPTION	QUANT.
1	270-075	lower looper	1	5	27.01-1141	needle plate bight width 1/8"	1
2	27.01-0501	feed dog main	1	6	280-0451/10	eccentric for main feed dog	1
3	781005-0-00	name plate showing machine class	1	7	280-0461/14	eccentric for subsidiary feed dog	1
4	27.277-0745	looper upper	1				
						On request:	
					270-401	see Tab. 38	
					270-075/2	see Tab. 38	
					27.277-074	see Tab. 38	
					270-D-074/1	see Tab. 38	
					PM.270-1882	see Tab. 38	
					G.274-401	see Tab. 38	
					001-D-7	see Tab. 38	

18

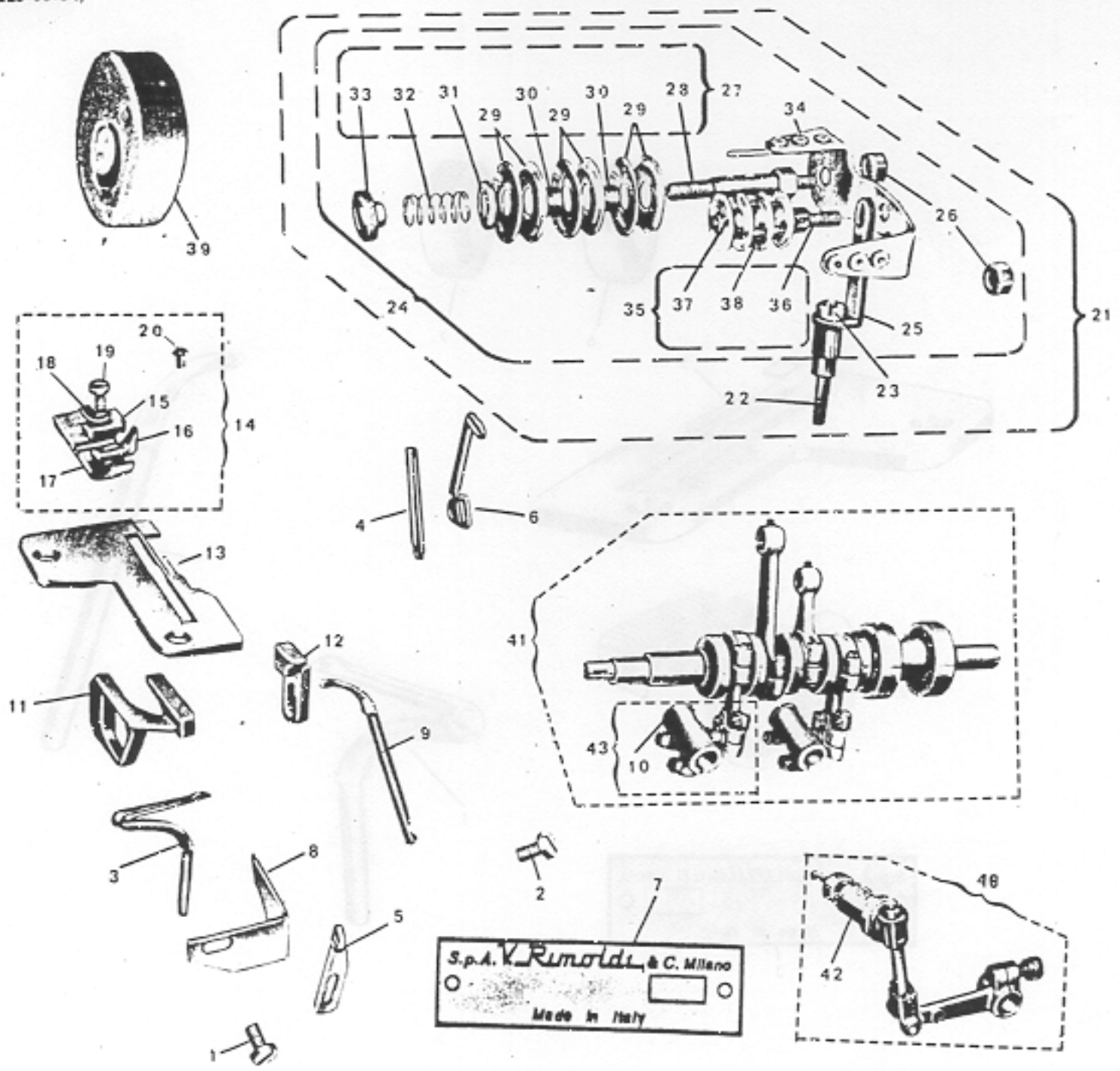

From the library of: Diamond Needle Corp

REF. N°	PART. N°	DESCRIPTION	QUANT.	REF. N°	PART. N°	DESCRIPTION	QUANT.
1	001-D-7	screw guide block fixing	1	23	001-G-10	screw	1
2	003-M-7	screw cap	3	24	G.27.21-C-700	tensions assembly	1
3	270-075	lower looper	1	25	27.21-C-702	guide block	1
4	270-263	thread guide for needle	1	26	057-R-5	nut	2
5	270-270	tensioner upper looper thread	1	27	PM.27.21-C-708	shaft with discs	1
6	270-274	take-up, needle thread	1	28	27.21-C-708	shaft	1
7	781006-0-00	name plate showing machine class	1	29	250-031	disc, tensioner	6
8	27.21-C-220	guard, feed dog	1	30	27.21-C-709	spacer	1
9	270-074	upper looper	1	31	240-035	retainer spring	1
10	27.21-C2-059	coupling	1	32	27.21-C-232	spring	1
11	PM.27.21-C-050	feed dog main	1	33	3710	knob	1
12	PM.28.21-C-051	feed dog subsidiary	1	34	G.27.21-C-703	plate with bush	1
13	PM.27.21-C-114/1	needle plate bight width 3/64" 1/16"	1	35	G.27.21-C-704	thread pulley with shaft	1
14	G.27.21-C-181/2	assembly presserfoot	1	36	3707	shaft	1
15	27.21-C-191/2	tongue	1	37	270-701	snap ring	1
16	270-183	block	1	38	PM.27.21-C-704	thread pulley	1
17	278-184/C2	slide	1	39	280-0461/40	eccentric for subsidiary and main feed dog	2
18	270-196	locator	1	40	G.27.21-C2-067/3	looper drive shaft with con-rods	1
19	004-L-7	screw	1	41	G.28.21-C2-009/4	main shaft assembly with con-rod	1
20	270-989	screw fixing block	1	42	27.21-C2-056	bush eccentric	1
21	AS.27.21-C-700	tensions assembly and thread pulley	1	43	PM.27.21-C2-059	con-rod with coupling	1
22	27.21-C-983	bolt	1				
					PM.27.21-C-114	see Tab. 38	
					G.27.21-C-181	see Tab. 38	
					G.27.21-C-181/1	see Tab. 38	



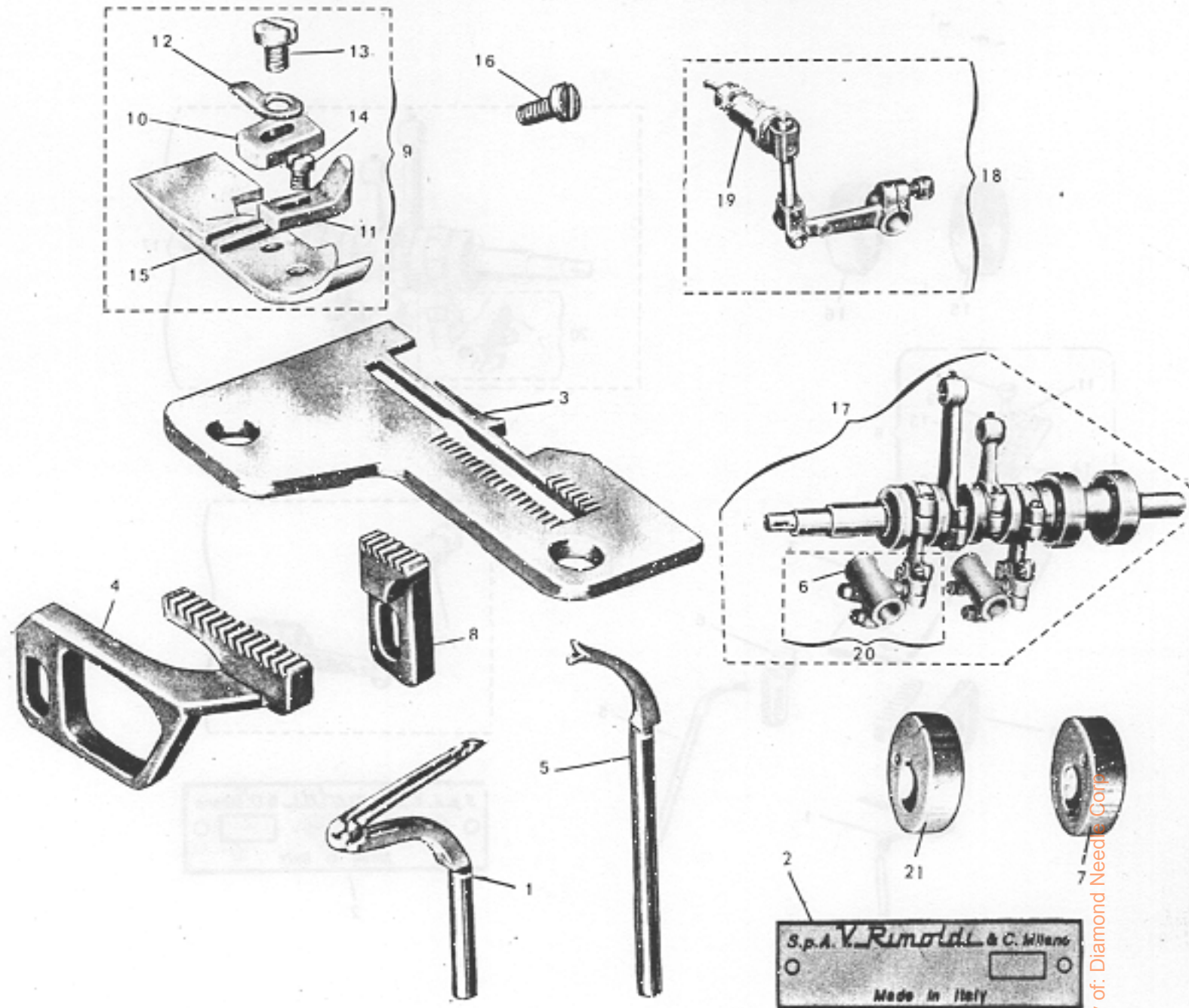

19

REF. N°	PART. N°	DESCRIPTION	QUANT.	REF. N°	PART. N°	DESCRIPTION	QUANT.
1	270-075	looper lower	1	11	270-183	plate	1
2	781007-0-00	name plate showing machine class	1	12	270-196	locator	1
3	27.21-1143	needle plate	1	13	004-L-7	screw	1
4	27.21-C-050	feed dog main	1	14	270-989	screw	1
5	27.221-C-074/1	looper upper blind	1	15	27.21-C-184	slide	1
6	27.21-C2-059	coupling	1	16	003-M-7	screw cap	1
7	280-0461/6	eccentric for subsidiary and main feed dog	1	17	G.28.21-C2009/4	main shaft assembly with con-rod	1
8	289-051	feed dgo subsidiary	1	18	G.27.21-C2-067/3	looper drive shaft with con-rods	1
9	G.27.21-CC-181	assembly presserfoot	1	19	27.21-C2-056	bush eccentric	1
10	27.21-CC-191	tongue	1	20	PM.27.21-C2-059	con-rod with coupling	1
				21	280-0461/30	eccentric for subsidiary feed dog	1

From the library of: Diamond Needle Corp.

20

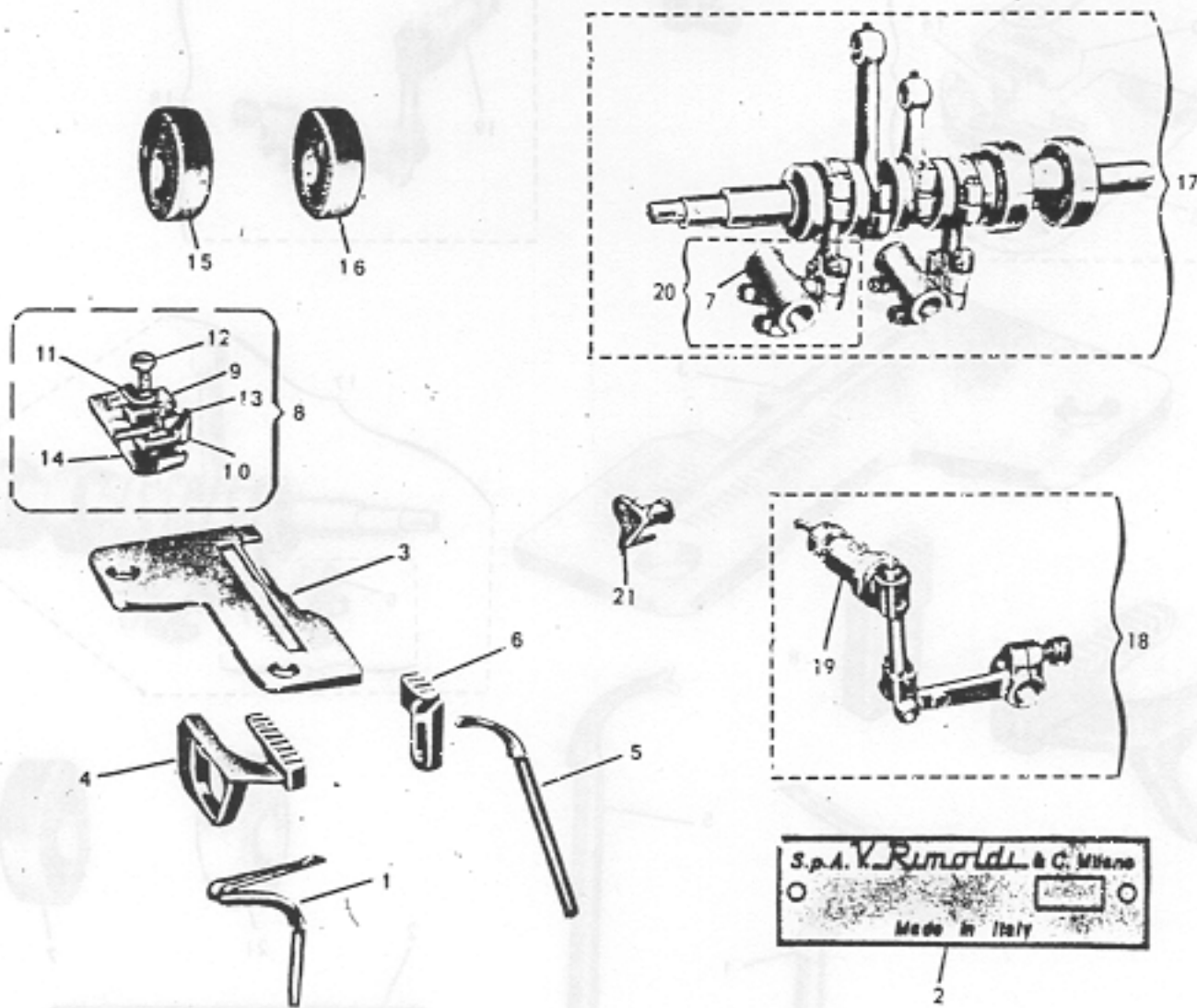

From the library of: Diamond Needle Corp

N° RIF.	N° DISEGNO	DENOMINAZIONE	QUANT.	N° RIF.	N° DISEGNO	DENOMINAZIONE	QUANT.
1	270-0751	looper lower	1	12	004 L-7	screw fixing tongue	1
2	781008-0-00	name plate showing machine class	1	13	270-989	screw fixing block	1
3	27.21-1141	needle plate bight width 3/64" - 1/16"	1	14	27.21-C-184	slide	1
4	27.21-C-050	feed dog main	1	15	280-0461/16	eccentric for subsidiary feed dog	1
5	270-074	looper, upper, with hole	1	16	280-0461/18	eccentric for main feed dog	1
6	289-051	feed dog subsidiary	1	17	G.28.21-C2009/4	main shaft assembly with con-rod	1
7	27.21-C2-059	coupling	1	18	G.27.21-C2-067/3	looper drive shaft with con-rods	1
8	G.27.21-CC-181	assembly presserfoot	1	19	27.21-C2-056	bush eccentric	1
9	27.21-CC-191	tongue	1	20	PM.27.21-C2-059	con-rod with coupling	1
10	270-183	block	1	21	G.270-262/3	thread take-up complete	1
11	270-196	locator	1				
						On request:	
					27.21-1143	see Tab. 38	
					272-092	see Tab. 38	

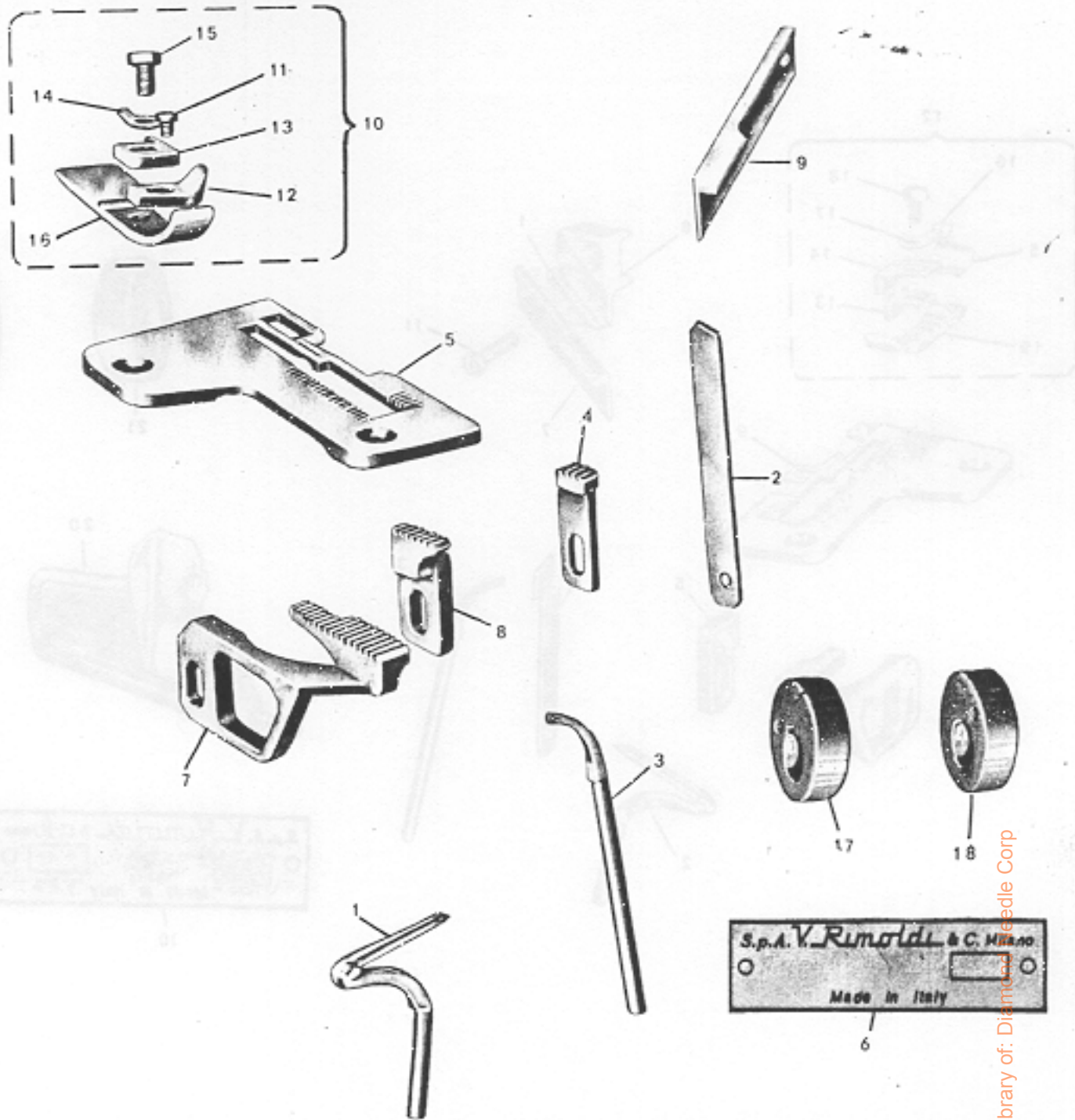

REF. N°	PART. N°	DESCRIPTION	QUANT.	REF. N°	PART. N°	DESCRIPTION	QUANT.
1	270-075	looper lower	1	10	G.278-181	presserfoot assembly complete	1
2	27.01-P9-113/1	knife lower	1	11	270-989	screw fixing block	1
3	27.277-0745	looper upper	1	12	270-183	block	1
4	278-052	feed dog	1	13	278-191	tongue	1
5	278-114	needle plate bight width 5/64"	1	14	270-196	locator	1
6	781011-0-00	plate machine class	1	15	004-L-7	screw fixing tongue	1
7	279-050	feed dog main	1	16	278-184	shoe	1
8	289-051	feed dog subsidiary	1	17	200-0451/12	eccentric for subsidiary feed dog	1
9	279-112	knife upper	1	18	280-0461/14	eccentric for main feed dog	1
					278-114/1	On request. see Tab. 38	

From the library of: Diamond Needle Corp

22

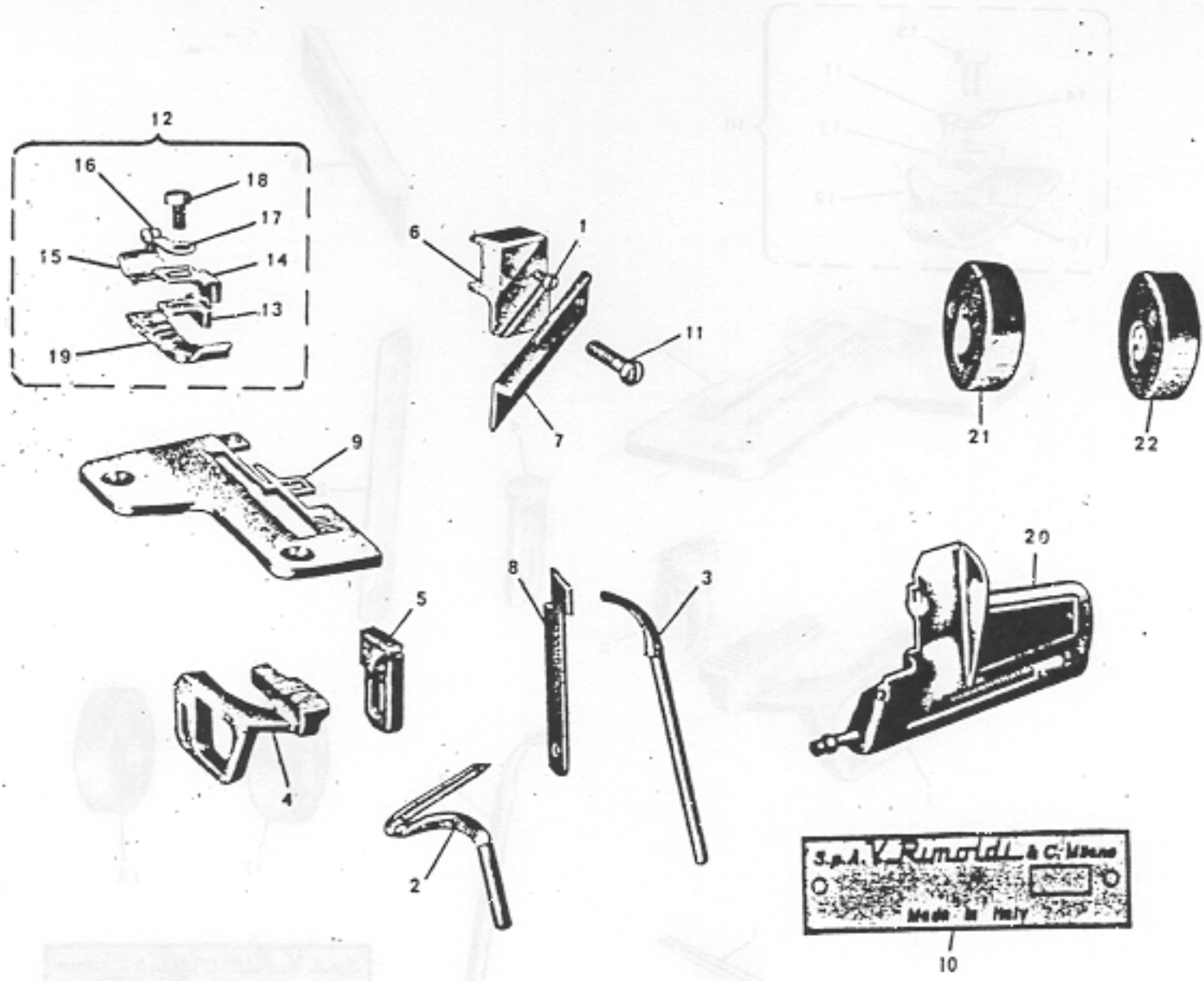

From the library of: Diamond Needle Corp

REF. N°	PART. N°	DESCRIPTION	QUANT.	REF. N°	PART. N°	DESCRIPTION	QUANT.
1	028-B-8	screw fixing block	1	12	G.279-181	presserfoot complete	1
2	270-075	looper lower	1	13	279-191	tongue	1
3	27.277-0745	looper upper	1	14	PM.279-183	block	1
4	279-050	feed dog main	1	15	275-185	plate	1
5	289-051	feed dog subsidiary	1	16	001-A-3,2	screw fixing plate	1
6	279-099	block upper knife holding	1	17	270-196	locator	1
7	279-112	knife upper	1	18	004-L-7	screw fixing tongue	1
8	279-113/1	knife lower	1	19	279-184	shoe	1
9	279-114	needle plate tight width 5/64"	1	20	G.279-216/2	cover plate, front, complete	1
10	781012-0-00	plate machine class	1	21	280-0451/12	eccentric for subsidiary feed dog	1
11	279-987	screw fixing upper knife	1	22	280-0461/14	eccentric for main feed dog	1
				On request:			
				270-075/2			
				27.277-074			
				see Tab. 38			
				see Tab. 38			

56

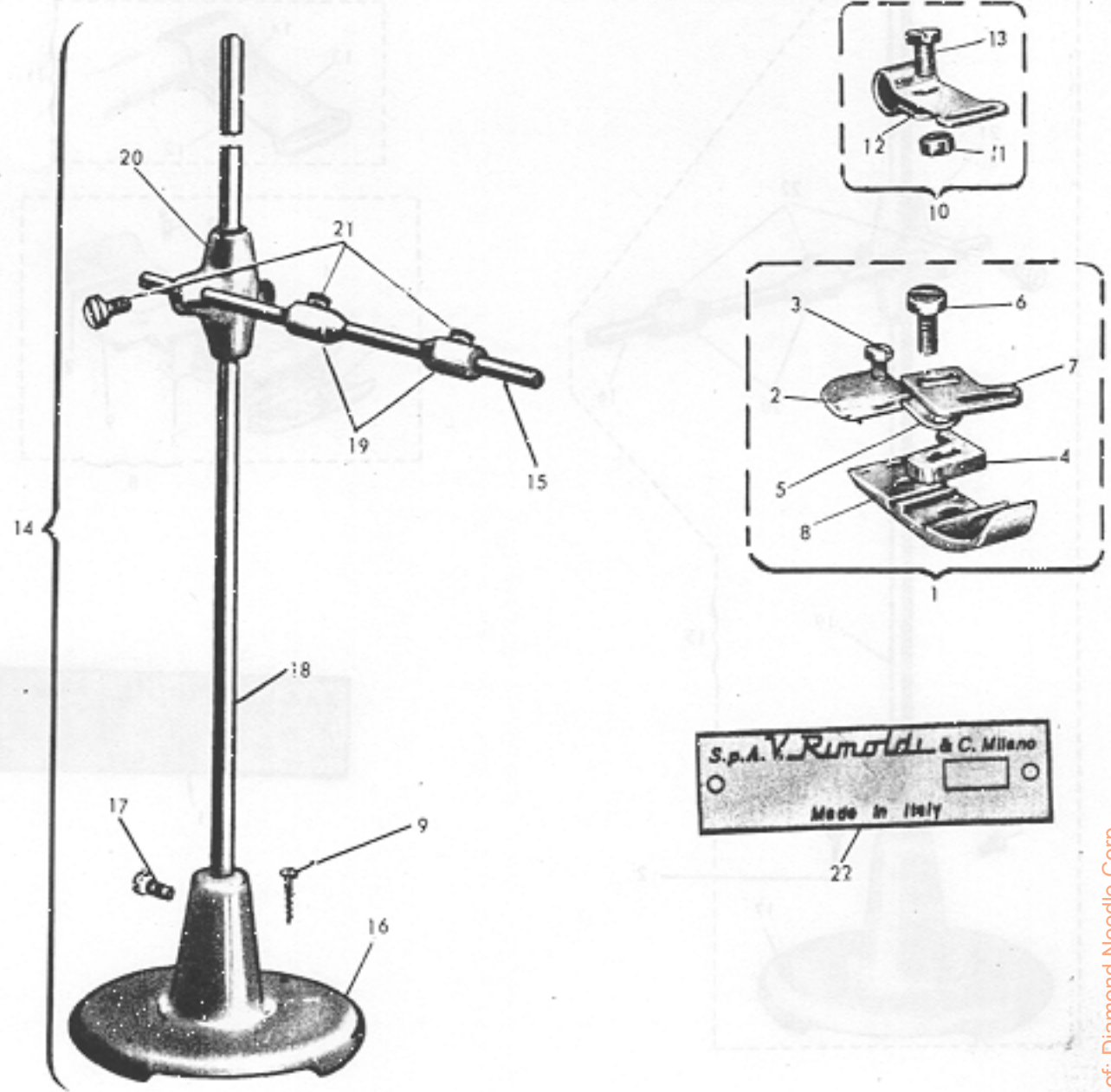

From the library of: Diamond Needle Corp

REF. N°	PART. N°	DESCRIPTION	QUANT.	REF. N°	PART. N°	DESCRIPTION	QUANT.
1	G.270-R-181	presserfoot complete	1	12	270-R-267	guide tape	1
2	270-185	plate	1	13	001-C-5,5	screw	1
3	001-A-3,2	screw	1	14	G.250-R-9373	support bobbin carrier	1
4	270-191	tongue	1	15	605-144	rod upper	1
5	270-196	locator	1	16	01141	base	1
6	004-L-8	screw	1	17	001-G-12	screw	1
7	270-R-071	plate	1	18	605-143	rod	1
8	270-R-184	shoe	1	19	605-723	rings cone	2
9	TS.20 x 30	screw	2	20	605-937	support	1
10	PM.270-R-267	guide tape	1	21	605-980	screw	4
11	057-A-3	nut	1	22	781030-0-00	plate machine class	1

24

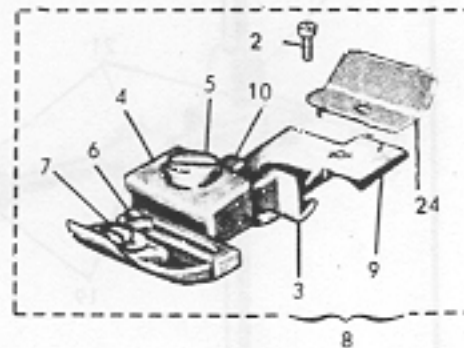
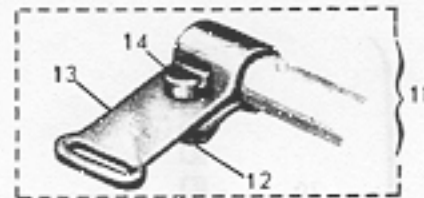
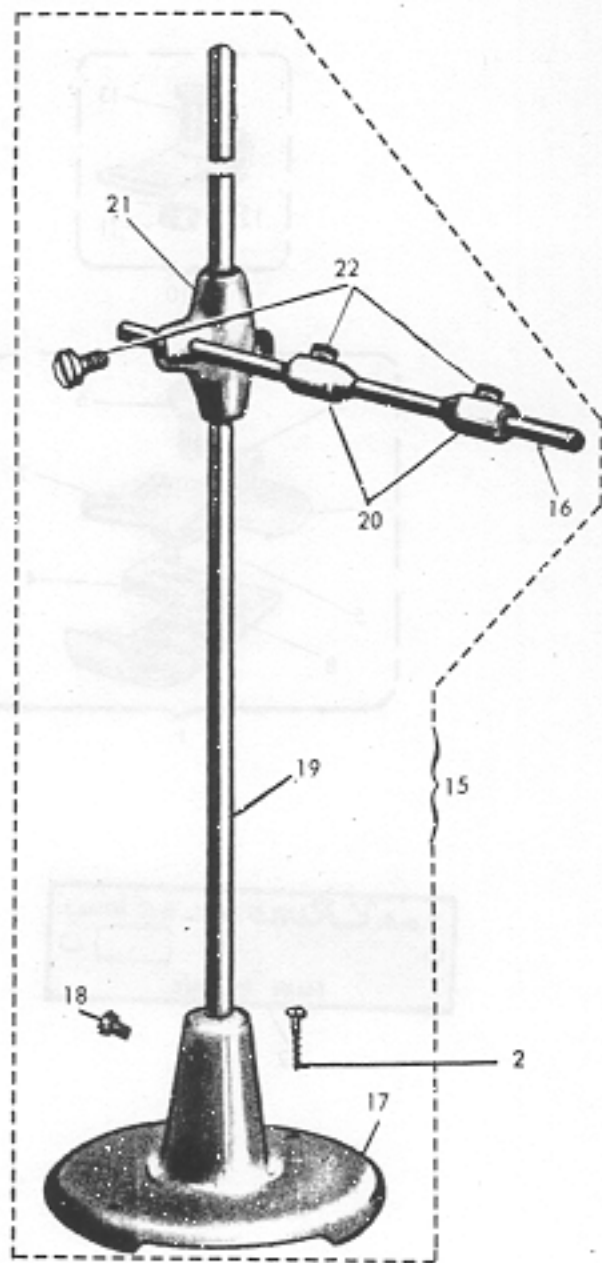

From the library of: Diamond Needle Corp

REF. N°	PART. N°	DESCRIPTION	QUANT.	REF. N°	PART. N°	DESCRIPTION	QUANT.
1	781031-0-00	plate machine class	1	13	270-R-267	guide tape	1
2	001-A-3,2	screw plate fixing	1	14	001-C-5,5	bolt	1
3	277-191	tongue presserfoot	1	15	G.250-R-9373	holder reel	1
4	27.77-183	plate	1	16	605-144	rod upper	1
5	004-L-9	screw tongue fixing	1	17	01141	base	1
6	27.277-R-071	plate tape guiding	1	18	001-G-12	screw	1
7	004-G-3	screw plate fixing	1	19	605-143	rod	1
8	G.277-R-181	presserfoot complete	1	20	605-723	ring conical	2
9	277-R-184	shoe presserfoot	1	21	605-937	support	1
10	27.77-195	locator	1	22	605-980	knob	4
11	PM.27.77-R-267	guide tape	1	23	TS. 20 x 30	screw for fixing reel holder	2
12	057-A-3	nut	1	24	277-185	plate chain guide	1
						On request:	
					270-075/2	see Tab. 38	
					27-277-074	see Tab. 38	
					28.00-87-0511	see Tab. 38	

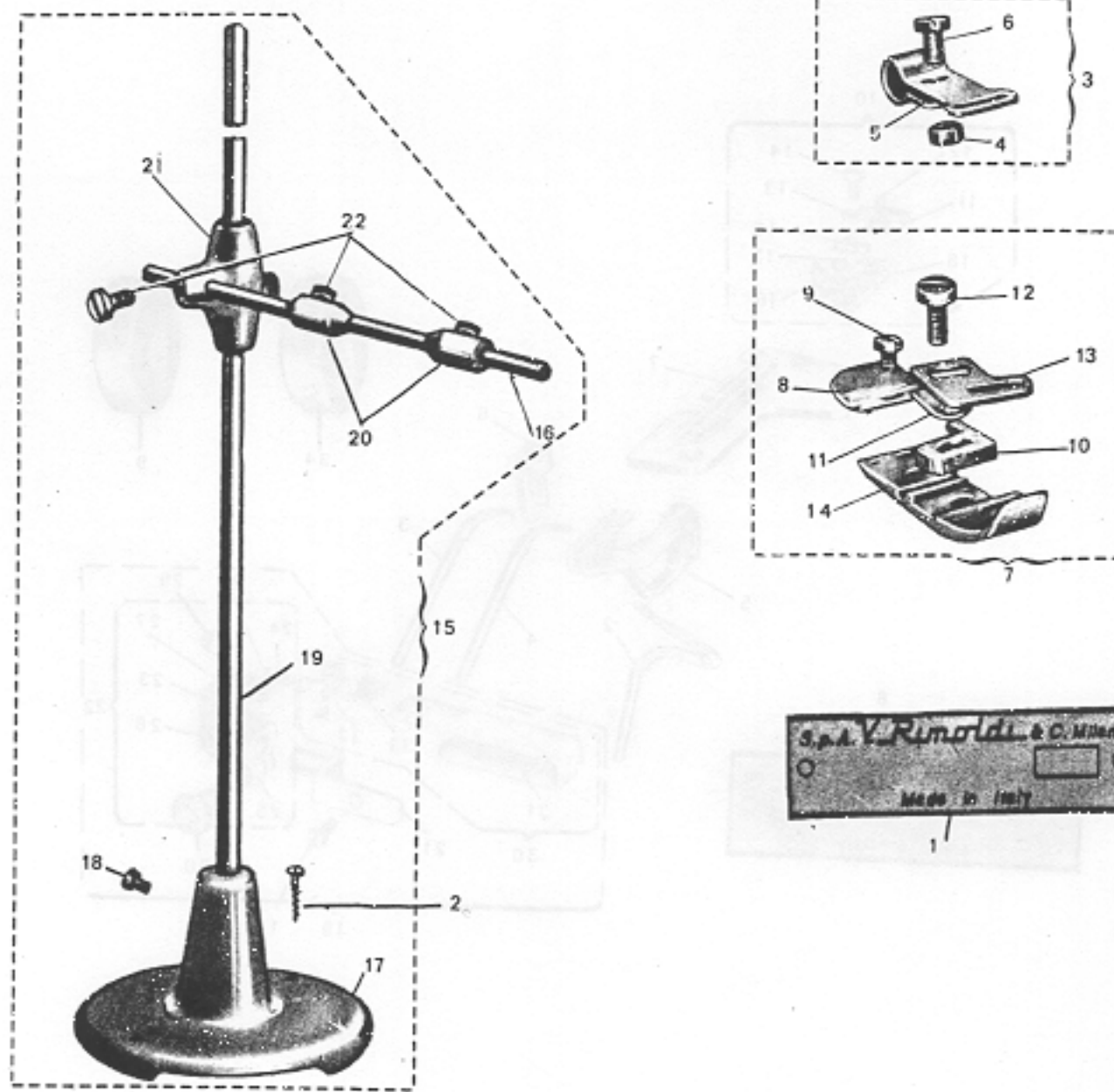

25

From the library of: Diamond Needle Corp

REF. N°	PART. N°	DESCRIPTION	QUANT.	REF. N°	PART. N°	DESCRIPTION	QUANT.
1	781032-0-00	plate machine class	1	12	004-L-8	bolt	1
2	TS 20 x 30	screw	2	13	270-R-071	plate	1
3	PM.270-R-267	tape guide	1	14	270-R-184	shoe	1
4	057-A-3	nut	1	15	G.250-R-9373	holder reel	1
5	270-R-267	tape guide	1	16	605-144	rod upper	1
6	001-C-5,5	bolt	1	17	01141	base	1
7	G.270-R-181	presserfoot complete	1	18	001-G-12	screw	1
8	270-185	plate	1	19	605-143	rod	1
9	001-A-3,2	screw fixing plate	1	20	605-723	ring conical	2
10	270-191	tongue	1	21	605-937	support	1
11	270-196	locator	1	22	605-980	screw	4

III. TECHNICAL DATA BY SUB-CLASS

HEAD No.	TECHNICAL CHARACTERISTICS						SPECIFIC USES	
	No. threads	Width of bight	Diff. pos.	SPEED		Knives		Sp. attachments on req.
				No. of revs. 1" max.	St. per inch			
228-00-01	3	1/8" 15/64"		7000	8-30	si	100 101 106 107	ASSEMBLY SEAMING WITH OR WITHOUT CURLED IN EDGES  For medium cut knit fabrics in wool, cotton, etc.
228-00-02	3	5/64" 9/64"		7000	8-30	si	100 101	For perfectly straight hanging seams on warpknit nylon fabrics etc.
228-00-03	3	5/64" 9/64"		7000	8-30	si	100 101 106 107	Same as 228-00-02 but with cutting device adjustable while the machine is in operation
228-00-04	3	1/8" 15/64"		6500	8-20	si	106	For medium and heavy fabrics, with a maximum presserfoot throw of 19/64" - maximum bight 15/64".
228-00-05	3	3/32" 5/32"		7000	8-30	si	100 101 106 107	Same as 228-00-01 but with a slightly narrower bight, for light cotton and woollen cut knit fabrics
228-00-06	3	3/64" 1/16"		6200	20-40	si	100	For closing the toes of nylon stockings
228-00-07	2	1/16" 5/64"		6200	20-40	si	100 106	For closing the toes of helanca and cotton socks
228-00-08	3	3/64" 1/16"		6200	14-40	si	100 106	For very light nylon warpknit fabrics, etc. (15 deniers), with very fine seam
228-00-11	3	5/64" 1/8"		7000	8-30	si	100 106 107	For very light and light woven fabrics (nylon, satin, very light flannel, etc.) with attachment to turn the fabric downwards into the seam.
228-00-12	3	3/32"		7000	8-30	si	100 106 107	For light woven fabrics, with attachment to turn the fabric upwards into the seam.
ASSEMBLY SEAMING WITH OR WITHOUT CURLED IN EDGES, WITH ATTACHMENTS AND/OR INSERTIONS								
228-01-01	3	1/8" 15/64"		7000	8-30	si	107	For medium cut knit fabrics in wool, cotton etc., with attachment for inserting a reinforcement tape into the seam
228-01-02	3	1/8" 15/64"		6500	8-20	si		For medium and heavy fabrics, with a maximum presserfoot throw of 19/64" - maximum bight 15/64". With attachment for inserting a reinforcement tape into the seam.
228-01-03	3	3/32" 5/32"		7000	8-30	si	107	Same as 228-01-01 but with a slightly narrower bight, for light cotton and woollen cut knit fabrics.

From the library of: Diamond Needle Corp



26

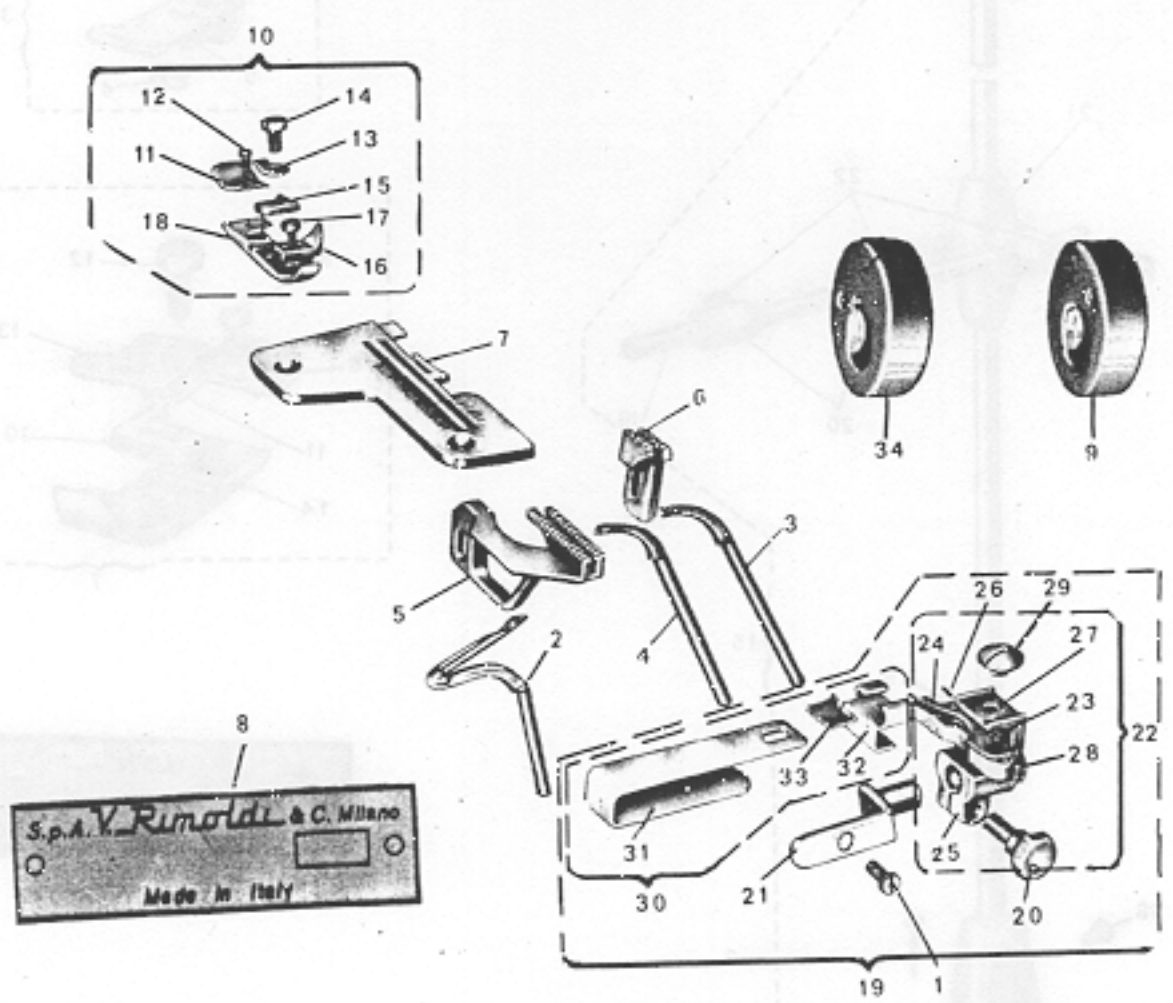

From the library of: Diamond Needle Corp

REF. N°	PART. N°	DESCRIPTION	QUANT.	REF. N°	PART. N°	DESCRIPTION	QUANT.
1	001-D-7	screw for fixing guide	1	18	275-184	shoe	1
2	270-075	looper lower	1	19	AS.275-413	hemming guide complete	1
3	270-D-074/1	looper upper blind	1	20	275-426	bolt	1
4	27-277-0745	looper upper with eye	1	21	PM.275-417	support	1
5	275-050	feed dog main	1	22	PM.275-408	body guide	1
6	285-051	feed dog subsidiary	1	23	275-403	screw	1
7	275-114	needle plate bight width 1/8"	1	24	275-411	plate	1
8	781060-0-00	plate machine class	1	25	275-408	body guide	1
9	280-0451/12	eccentric for subsidiary feed dog	1	26	275-410	pin	2
10	G.275-181	presserfoot complete	1	27	275-409	hinge	1
11	275-185	plate	1	28	275-425	knob	1
12	001-A-3,2	screw plate fixing	1	29	275-404	screw	1
13	270-196	locator	1	30	PM.275-407	plate with spring	1
14	004-L-7	screw tongue fixing	1	31	275-407	plate	1
15	275-191	tongue	1	32	275-415	guide sliding	1
16	275-183	block	1	33	275-416	spring	1
17	270-989	screw	1	34	280-0451/8	eccentric for main feed dog	1
						On request:	
					270-075/2	see tab. 38	
					27-277-074	see tab. 38	
					275-1141	see tab. 38	
					PM.275-1882	see tab. 38	
					285-0511	see tab. 38	

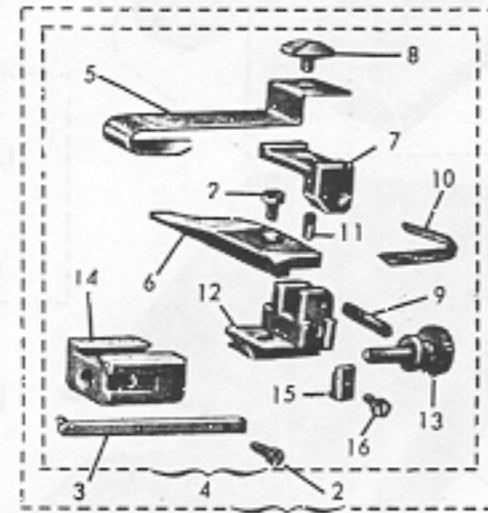
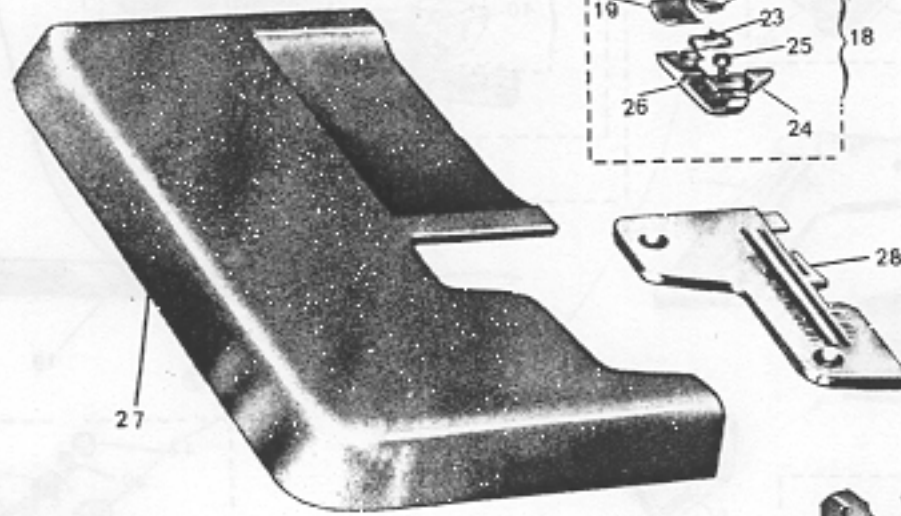

From the library of: Diamond Needle Corp

REF. N°	PART. N°	DESCRIPTION	QUANT.	REF. N°	PART. N°	DESCRIPTION	QUANT.
1	AS.275-B-413	hemming guide complete	1	16	005-D-5	screw	1
2	001-D-6	screw	2	17	781061-0-00	plate machine class	1
3	PM.275-B-417	support	1	18	G.275-B-181	presserfoot complete	1
4	G.275-B-413	guide hemming	1	19	275-185	plate	1
5	275-B-407	plate hemming	1	20	001-A-3,2	screw plate fixing	1
6	275-B-411	guide	1	21	275-B-196	locator	1
7	275-B-409	block	1	22	004-L-7	screw tongue fixing	1
8	275-404	screw	1	23	275-B-191	tongue	1
9	275-B-410	pin threaded	1	24	275-B-183	block	1
10	275-B-430	spring leaf	1	25	270-989	screw	1
11	275-B-403	screw stop	1	26	275-B-184	shoe	1
12	275-B-406	slide	1	27	G.275-B-210/3	work plate	1
13	275-B-425	screw adjustment	1	28	275-B-114	needle plate bight width 1/8"	1
14	275-B-408	body guide	1	29	275-B-050	feed dog main	1
15	275-B-418	locator	1				
					AS.275-B-413/1	On request: Tab. 39	

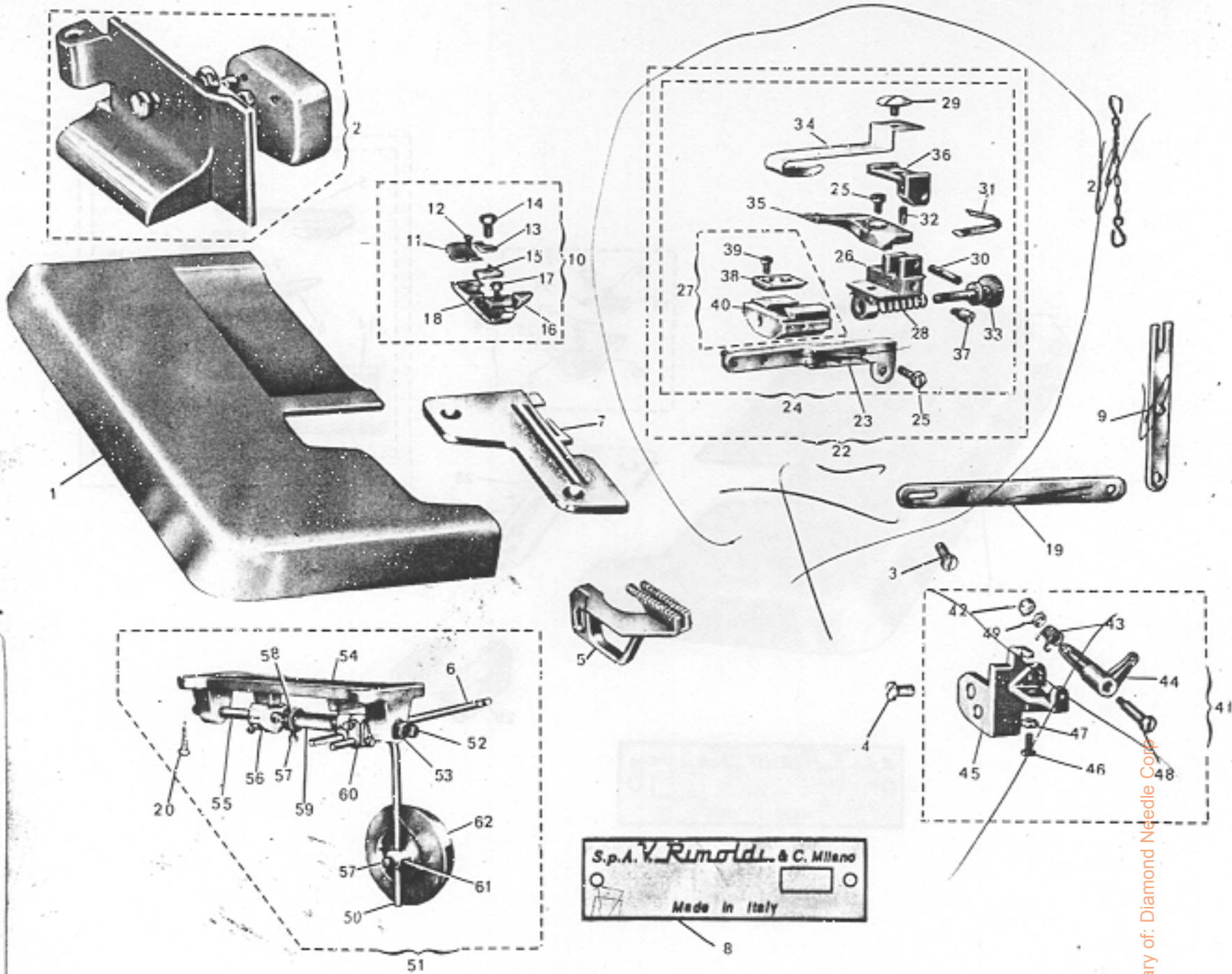

From the library of: Diamond Needle Corp.

REF. N°	PART. N°	DESCRIPTION	QUANT.	REF. N°	PART. N°	DESCRIPTION	QUANT.
1	G.275-B-210/3	work plate	1	31	275-B-430	spring leaf	1
2	G.262-BK-209/1	cover side	1	32	275-B-403	screw stop	1
3	012-H-5	screw for lever junction	3	33	275-BS-4252	screw adjustment	1
4	001-G-10	screw fixing lever assembly	2	34	275-B-407	plate hem	1
5	275-B-050	feed dog main	1	35	275-B-411	guide	1
6	620-565	rod	1	36	275-B-409	block	1
7	275-B-114	needle plate bight width 1/8"	1	37	275-BS-6412	pin threaded	1
8	781062-0-00	plate machine class	1	38	275-BS-4142	guide	1
9	275-BS-6002	lever moving vertical guide	1	39	004-A-3,2	screw	2
10	G.275-B-181	presserfoot complete	1	40	275-BS-4082	body	1
11	275-185	plate	1	41	G.275-BS-6012	lever assembly for moving guide	1
12	001-A-3,2	screw fixing plate	1	42	053-D-4	nut	1
13	275-B-196	locator	1	43	275-BS-6052	spring	1
14	004-L-7	screw fixing tongue	1	44	275-BS-6032	transmission	1
15	275-B-191	tongue	1	45	275-BS-6012	support	1
16	275-B-183	block	1	46	039-D-6	screw	1
17	270-989	screw	1	47	057-B-3	nut	1
18	275-B-184	shoe	1	48	275-BS-6062	pin	1
19	275-BS-5992	lever horizontal connecting	1	49	063-N-4	washer	1
20	TS. 22 x 35	screw fixing knee control	4	50	270-573	rod	1
21	PM. 275-BS-1482	chain	1	51	G. 620-570	knee control complete	1
22	AS.275-BS-4132	assembly movable hem guide	1	52	270-998	screw pointed	2
23	PM.275-BS-4172	support	1	53	059-P-8	nut hexagonal	2
24	G.275-BS-4132	guide complete	1	54	620-570	support	1
25	001-D-6	screw	2	55	270-571	shaft	1
26	275-BS-4062	slide	1	56	270-579	anchor	1
27	PM.275-BS-4082	body guide	1	57	038-M-9	screw hexagonal	9
28	275-BS-4152	spring	1	58	270-720	ring spring tensioning	1
29	275-404	screw	1	59	270-575	spring	1
30	275-B-410	pin threaded	1	60	620-572	union	2
			1	61	270-574	disc	1
			1	62	270-582	pad disc	1

On request:  
AS.275-BS-4132/1 Tab. 39

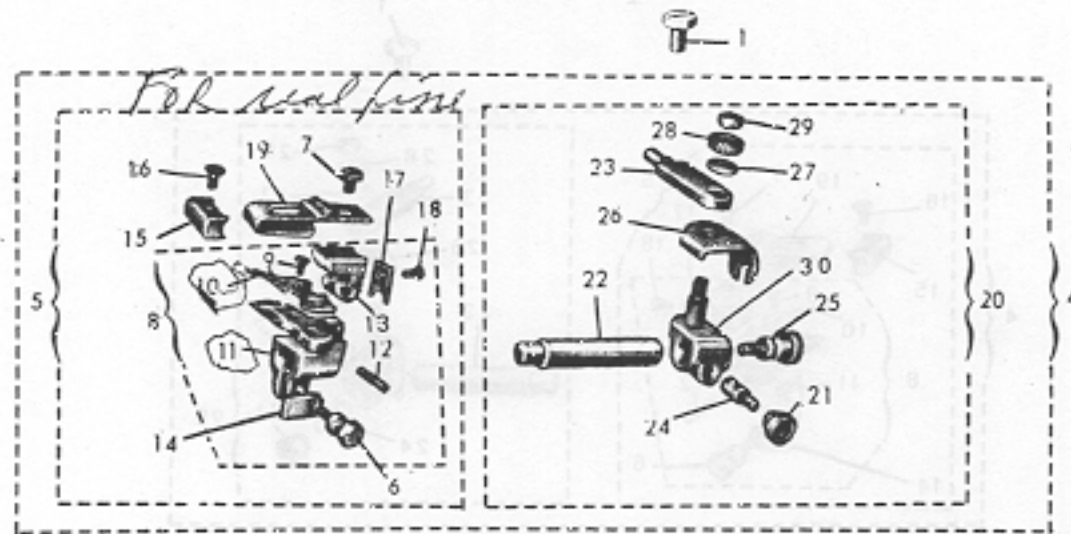
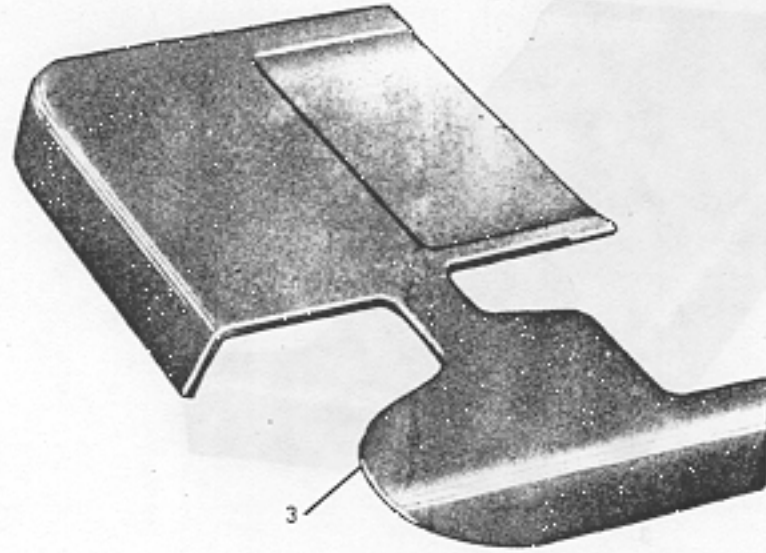

29

From the library of: Diamond Needle Corp

REF. N°	PART. N°	DESCRIPTION	QUANT.	REF. N°	PART. N°	DESCRIPTION	QUANT.
1	039-R-8,5	bolt guide fixing	1	16	255-404	screw	1
2	791064-0-00	plate machine class	1	17	27.53-2221	plate guide blocking	1
3	G.27.53-210/3	work plate complete	1	18	001-C-4	screw	1
4	AS.27.53-4132	hemming guide complete	1	19	PM.255-434	spring with hinge	1
5	PM.27.53-4031	guide	1	20	G.27.53-3792	attachment complete,	1
6	275-426	screw locking	1	21	250-980	knob	1
7	275-404	screw	1	22	27.53-4011	rod	1
8	PM.275-408	body with hinge	1	23	27.53-4172	support	1
9	275-404	screw	2	24	27.53-4181	pawl	1
10	275-411	plate	1	25	27.53-4251	knob	1
11	275-408	body guide	1	26	27.53-2201	fork	1
12	275-410	pin	1	27	27.53-4121	washer spring	1
13	275-409	hinge	1	28	27.53-4261	knob	1
14	27.53-2231	plate stop	1	29	27.53-2211	nut	1
15	255-415	block	1	30	27.53-4071	support rotating	1

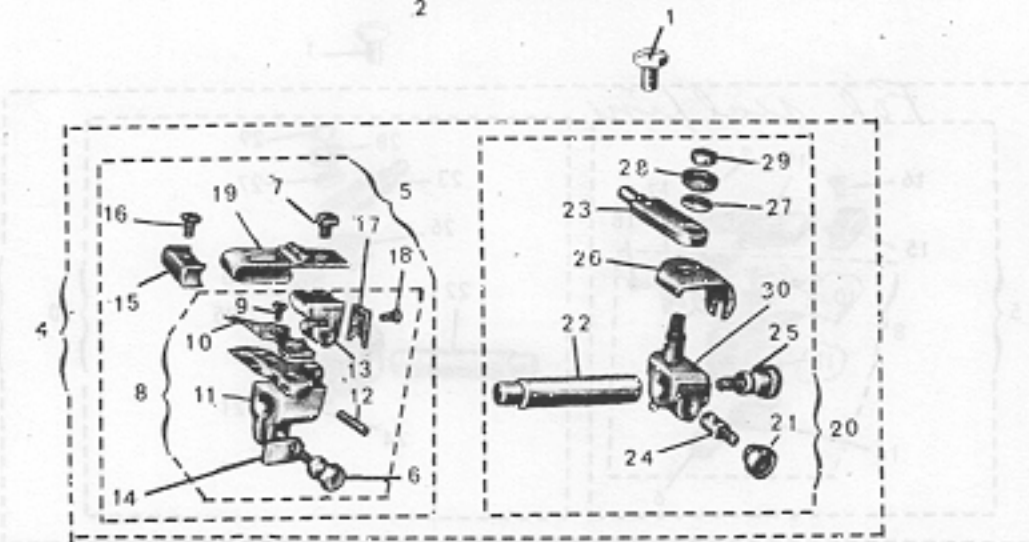
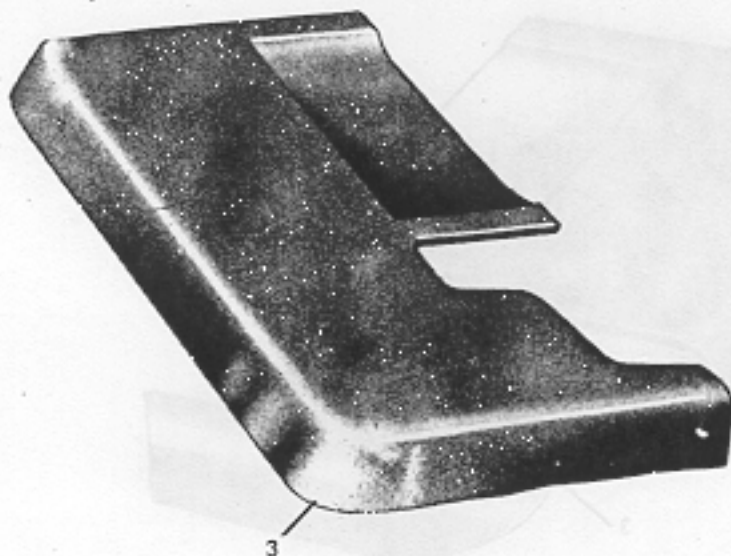

30

From the library of: Diamond Needle Corp

REF. N°	PART. N°	DESCRIPTION	QUANT.	REF. N°	PART. N°	DESCRIPTION	QUANT.
1	039-R-8,5	screw guide fixing	1	16	255-404	screw	1
2	781065-0-00	plate machine class	1	17	27.53-2221	plate guide blocking	1
3	G.27.54-210/3	work plate complete	1	18	001-C-4	screw	1
4	AS.27.53-4132	hemming guide complete	1	19	FM.255-434	spring with hinge	1
5	PM.27.53-4081	guide	1	20	G.27.53-3792	attachment complete	1
6	275-426	screw locking	1	21	250-980	knob	1
7	275-404	screw	1	22	27.53-4011	rod	1
8	PM.275-408	body with hinge	1	23	27.53-4172	support	1
9	275-404	screw	2	24	27.53-4181	pawl	1
10	275-411	plate	1	25	27.53-4251	knob	1
11	275-408	body guide	1	26	27.53-2201	fork	1
12	275-410	pin	1	27	27.53-4121	washer spring	1
13	275-409	hinge	1	28	27.53-4261	knob	1
14	27.53-2231	plate stop	1	29	27.53-2211	nut	1
15	255-415	block	1	30	27.53-4071	support rotating	1

64

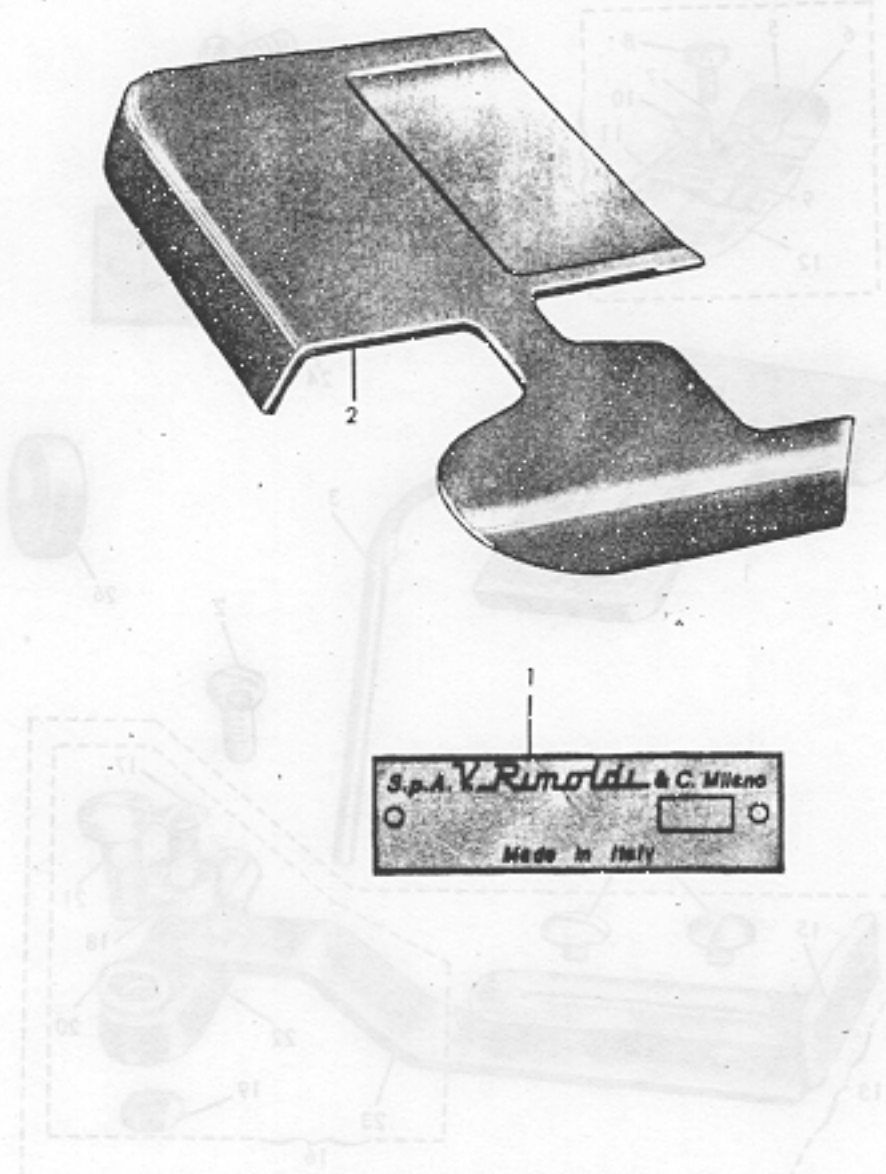

From the library of: Diamond Needle Corp

REF. N°	PART. N°	DESCRIPTION	QUANT.	REF. N°	PART. N°	DESCRIPTION	QUANT.
1	781066-0-00	plate machine class	1				
2	G.27.53210/3.	work plate complete	1				

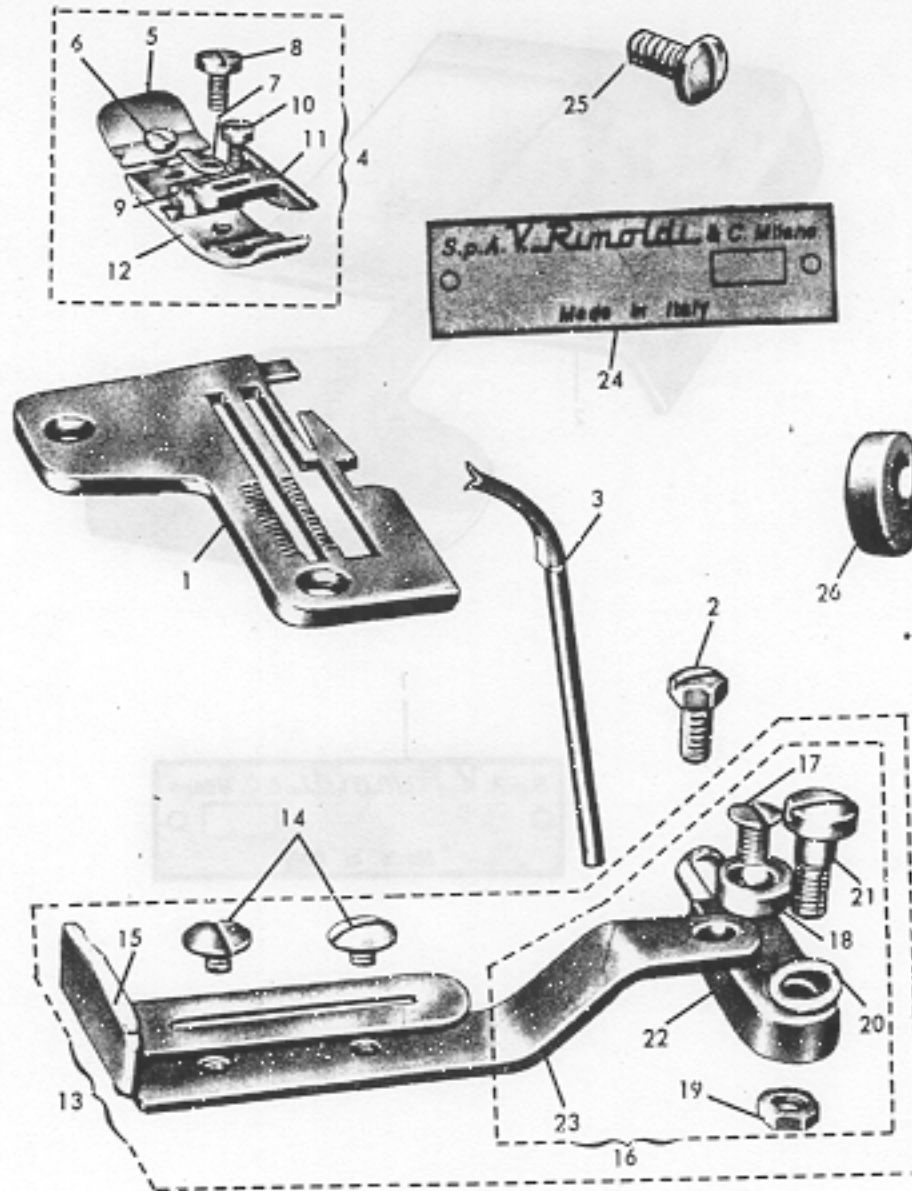

From the library of: Diamond Needle Corp

REF. N°	PART. N°	DESCRIPTION	QUANT.	REF. N°	PART. N°	DESCRIPTION	QUANT.
1	270-1142	needle plate bight width 11/64"	1	14	255-404	screws	2
2	039-R-8,5	screw guide fixing	1	15	PM.276-B-403	guide	1
3	270-D-074/1	looper upper blind	1	16	G.276-B-403/1	support complete	1
4	G.274-B1-1811	presserfoot complete	1	17	032-F-6,5	screw for eccentric	1
5	270-185	plate	1	18	605-412	eccentric	1
6	001-A-3,2	screw plate fixing	1	19	057-E-4	nut	1
7	270-196	locator	1	20	276-B-412	washer spring	1
8	004-L-7	screw tongue fixing	1	21	011-E-13	screw collar	1
9	270-191	tongue	1	22	276-B-417/1	support guide	1
10	001-A-5,5	screw guide fixing	1	23	276-B-407/1	support rotating	1
11	274-B1-1921	guide	1	24	781110-0-00	plate machine class	1
12	276-B-184	shoe	1	25	003-M-7	screw cap	1
13	AS.276-B-403/1	guide rotating	1				
						On request:	
						270075	Tab. 38

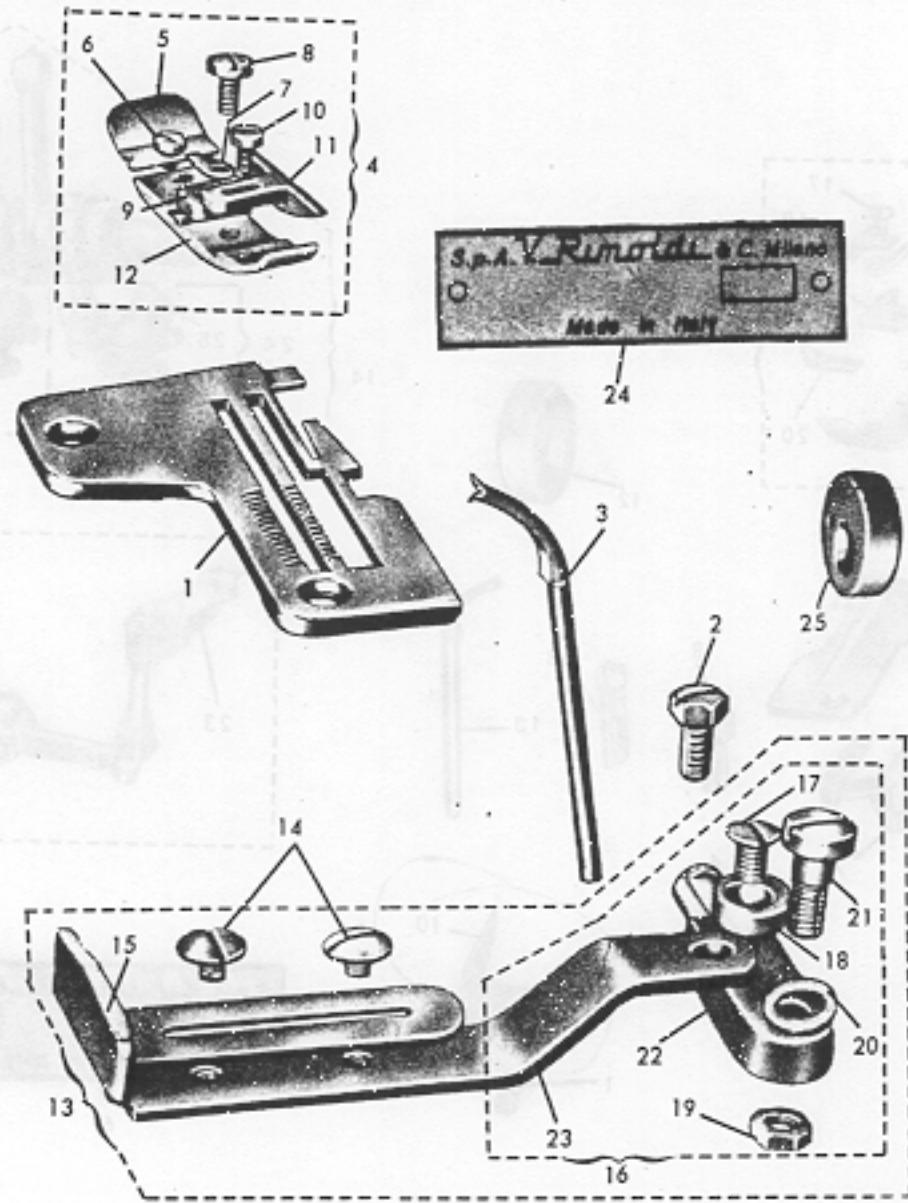

From the library of: Diamond Needle Corp

REF. N°	PART. N°	DESCRIPTION	QUANT.	REF. N°	PART. N°	DESCRIPTION	QUANT.
1	270-1142	needle plate bight width 11/64"	1	14	255-404	screws	2
2	039-R-8,5	screw guide fixing	1	15	PM-276-B-403	guide	1
3	270-D-074/1	looper upper blind	1	16	G.276-B-403/1	support complete	1
4	G.274-B1-1811	presserfoot complete	1	17	032-F-6,5	screw for eccentric	1
5	270-185	plate	1	18	605-412	eccentric	1
6	001-A-3,2	screw plate fixing	1	19	057-E-4	nut	1
7	270-196	locator	1	20	276-B-412	washer spring	1
8	004-L-7	screw tongue fixing	1	21	011-E-13	screw collar	1
9	270-191	tongue	1	22	276-B-417/1	support guide	1
10	001-A-5,5	screw guide fixing	1	23	276-B-407/1	support rotating	1
11	274-B1-1921	guide	1	24	781111-0-00	plate machine class	1
12	276-B-184	shoe	1	25	280-0451/6	eccentric feed dog	2
13	AS.276-B-403/1	guide rotating	1				

On request:  
270075      Tab. 38  
27.277-0745      Tab. 38

5



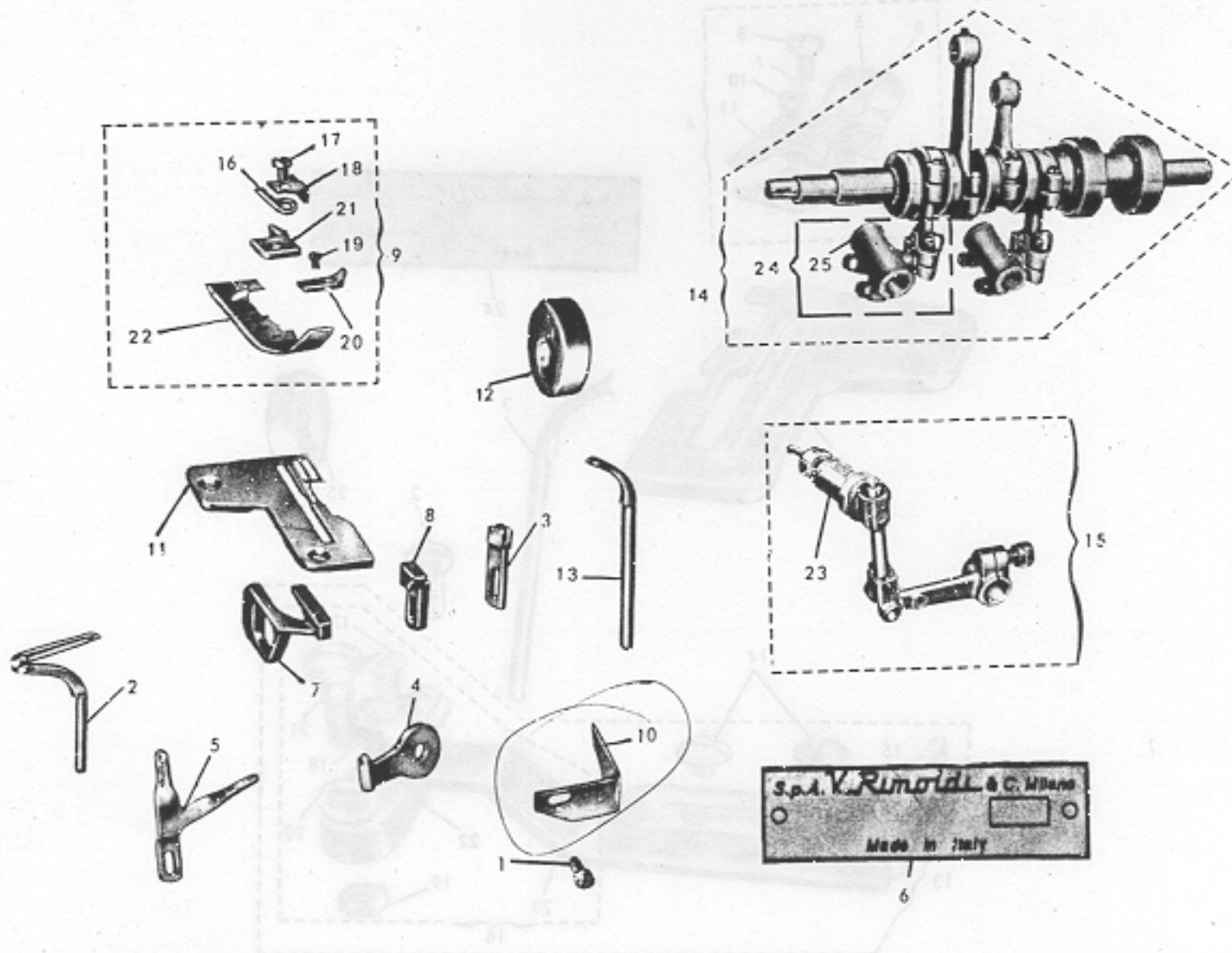

34

From the library of: Diamond Needle Corp

N° RIF.	N° DISEGNO	DENOMINAZIONE	QUANT.	N° RIF.	N° DISEGNO	DENOMINAZIONE	QUANT.
1	001-D-7	screw guide block fixing	1	14	G.28.21-C2-009/4	main shaft assembly	1
2	270-0751	looper lower	1	15	G.27.21-C2-067/3	looper drive shaft with connecting rods	1
3	272-B-052	feed dog chaining	1	16	270-196	locator	1
4	272-B-270	tensioner upper looper thread	1	17	004-L-8	screw	1
5	272-B-272	tensioner lower looper thread	1	18	27.21-C-183/1	plate	1
6	781116-0-00	name plate showing machine class	1	19	270-989	screw	1
7	PM.27.21-C-050	feed dog main	1	20	270-183	block	1
8	PM.28.21-C-051	feed dog subsidiary	1	21	27.21-C-191/1	tongue	1
9	G.27.21-C-181/1	assembly presserfoot	1	22	27.21-C-184/1	slide	1
10	27.21-C-220	guard, holder feed dog	1	23	27.21-C2-056	bush eccentric	1
11	PM.27.21-S-114	needle plate	1	24	PM.27.21-C2-059	con-rod with coupling	1
12	280-0461/40	eccentric for main and subsidiary feed dog	2	25	27.21-C2-059	coupling	1
13	270-074	looper upper	1				

68

SOLENOID  
CHAIN CUTTING  
ATTACHMENT  
(W1) 100

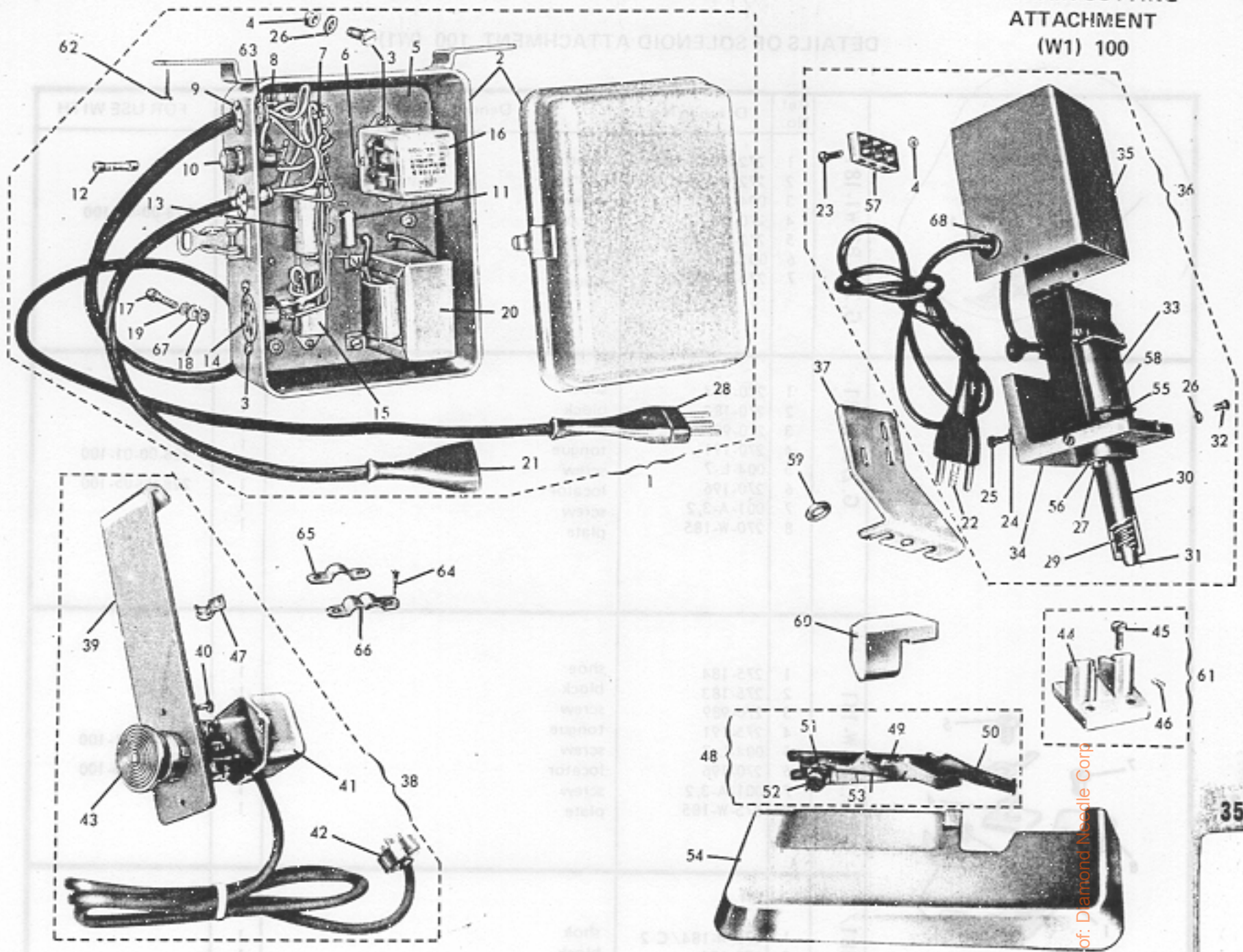

WARNING: the apparatus is designed for 220 V. For different voltages run through an autotransformer type SUT. 1745.00 with relative connectors type PM. T 11-127.

REF. N°	PART. N°	DESCRIPTION	QUANT.	REF. N°	PART. N°	DESCRIPTION	QUANT.
1	AS.270-W1-333	control box complete	1	35	PM.270-W1-343	cover solenoid	1
2	G.270-W1-333	control box electric	1	36	AS.270-W1-351	assembly complete solenoid	1
3	C.001-C-10	screw	11	37	270-W1-323	bracket	1
4	057-B-3	nut	13	38	G.270-W-3340	push-button complete	1
5	270-W1-373	panel	1	39	270-W-3300	bracket push-button	1
6	270-W1-378	base	1	40	001-E-5	screw	4
7	T 11-22	anchoring	1	41	270-W-3310	cover	1
8	T 11-30	cable terminal	1	42	270-W-3700	plug 4-pin	1
9	270-W1-3721	grommet	2	43	270-W-3340	push-button	1
10	270-W1-363	fuse holder	1	44	270-W-6400/3	bracket slide guide	1
11	T 11-16/3	resistor	1	45	008-A-12	screw	1
12	T 11-33/3	fuse	1	46	270-716	screw	1
13	T 11-21	condenser electronic	1	47	122-T-37	guide cable	2
14	270-W-3680	socket push-button	1	48	G.270-W-3220/1	lever complete	1
15	T 11-14	rectifier	1	49	270-W-3220	lever chain cutting	1
16	270-W1-379	relay	1	50	PM.270-W-0760/1	lever, presserfoot holder	1
17	C.001-E-30	screw	3	51	270-W-3280	washer	1
18	053-D-4	nut	3	52	270-W-3250	screw for spring	1
19	063-L-4	washer	6	53	270-W-3240	spring knife return	1
20	T 11-13	transformer	1	54	G.270-W1-210/3	work plate	1
21	270-W1-369	socket	1	55	270-W-3540	washer	4
22	270-W1-372	plug with earth	2	56	633-710/1	washer	2
23	C.001-C-14	screw	2	57	122-T-215	board terminal	1
24	064-L-5	washer	3	58	001-E-8	screw	4
25	270-W-3550	screw	3	59	065-C-6	washer	2
26	270-W1-355	washer star	12	60	280-253 TC 30	gasket for slide guide	1
27	001-E-12	screw	2	61	G.270-W-6400/3	bracket slide guide	1
28	T 11-126	plug with earth	1	62	TT 20 x 25	screw wood	4
29	270-W1-346	spring	1	63	270-W1-328	holder cable	2
30	270-W1-345	sleeve	1	64	270-453	nail for cable guide	30
31	270-W1-349	contact point	1	65	546	guide single cable	10
32	C.001-C-7	screw	3	66	547	guide double cable	5
33	270-W1-351	solenoid	1	67	T 11-355	washer star	3
34	PM.270-W1-332	bracket	1	68	270-W1-327	grommet	1

From the library of: Diamond Needle Corp

III. TECHNICAL DATA BY SUB-CLASS

HEAD No.	TECHNICAL CHARACTERISTICS						SPECIFIC USES	
	No. threads	Width of bight	Diff. pos.	S P E E D		Knives		Sp. attachments on req.
				No. of revs. 1" max.	St. per inch			
228-10-01	3/2	5/64" 1/8"		7000	8-30	si	100 106 107	HEMMING For wetting knit fabrics in general with invisible seam on right side, with fixed hinged wetting folder - with a blind looper to work also with 2 thread.
228-10-02	3/2	5/64" 1/8"		7000	8-30	si	100 106 107	With folder, throat plate, feed dog and presserfoot specially designed for wetting along the non-stretchy direction of warpknit, jersey fabrics, etc. with invisible seam on right side, with a blind looper to work also with 2 threads
228-10-03	3/2	5/64" 1/8"		7000	8-30	si	100 106 107	Same as 228-10-02 but with wetting folder moveable by means of knee-press, guaranteeing a regular hem even at cross-seams
228-10-05	3/2	5/64" 1/8"		7000	8-30	si	100 106 107	For wetting of knit fabrics with invisible seam on right side, with swingout wetting folder and with work plate cut out to accept preclosed sleeves, with blind looper to work also with 2 threads
228-10-06	3/2	5/64" 1/8"		7000	8-30	si	100 106 107	For wetting of knit fabrics with invisible seam on right side, with blind looper to work also with 2 threads
228-10-07	3/2	5/64" 1/8"		7000	8-30	si	100 106 107	Same as 228-10-01 but with special work plate cut out to accept preclosed sleeves
228-28-01	2	1.8" 15/64"		7000 6500	8-14 6-7	si	100 106 107 120 121 900 901 902	OVEREDGING For serging and/or overedging light and medium woven and knit fabrics where the use of the differential is particularly requested.
228-28-02	3/2	1.8" 15/64"		7000 6500	8-14 6-7	si	100 106 107 120 121 900 901 902	Same as 228-28-01 but with looper to work also with three threads
228-28-07	3	3/32" 9/64"		6000	14-40	si	100 106 107	For serging and/or overedging headsquares, veils, scarves, etc. made from lightweight fabrics such as nylon, silk, japonette, etc. turning the edge of the fabric into the seam.

From the library of: Diamond Needle Co.

DETAILS OF SOLENOID ATTACHMENT 100 (W1)













	Ref. No.	Drawing No.	Denomination	Quant	FOR USE WITH				
	G.272-B2-W1-181	1 272-B2W1-184 2 272-B-183 3 004-L-8 4 270-196 5 272-B-191 6 001-A-4 7 275-W-185	shoe plate screw locator tongue screw plate	1 1 1 1 1 1 1	228-00-02-100				
		G.270-W-181	1 270-184 2 270-183 3 270-989 4 270-191 5 004-L-7 6 270-196 7 001-A-3,2 8 270-W-185	shoe block screw tongue screw locator screw plate	1 1 1 1 1 1 1 1	228-00-01-100 228-00-05-100			
			G.275-W-181	1 275-184 2 275-183 3 270-989 4 275-191 5 004-L-7 6 270-196 7 001-A-3,2 8 275-W-185	shoe block screw tongue screw locator screw plate	1 1 1 1 1 1 1 1	228-10-01-100 228-10-06-100		
				G.27.21-CW-181/2	1 278-W-184/C 2 2 270-183 3 270-989 4 2721-C-191/2 5 004-L-7 6 270-196 7 001-A-3,2 8 270-W-185	shoe block screw tongue screw locator screw plate	1 1 1 1 1 1 1 1	228-00-06-100	
					G.27.21-CCW-181	1 2721-CC-W-184 2 270-183 3 270-989 4 2721-CC-191 5 004-L-7 6 270-196 7 001-A-3,2 8 270-W-185	shoe block screw tongue screw locator screw plate	1 1 1 1 1 1 1 1	228-00-07-100
						G.27.54-W1-210/3		G.275-B W1-210/3	
						FOR USE WITH		FOR USE WITH	
228-10-06					228-10-02 - 228-10-03				
					G.27.53-W1-210				
	FOR USE WITH								
228-10-05 - 228-10-07									

From the library of: Diamond Needle Corp

36

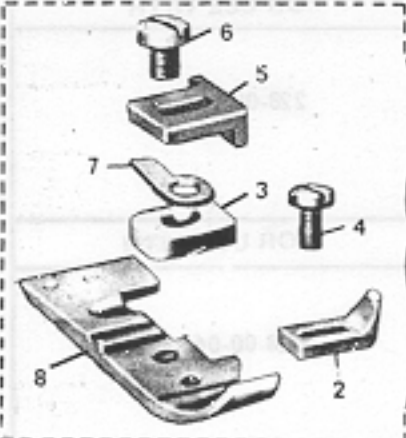
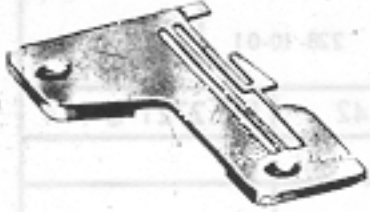

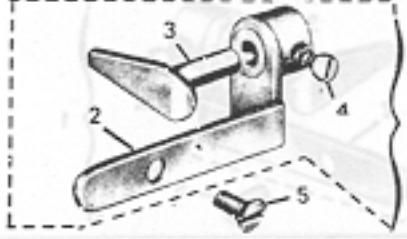









70

PARTS SUPPLIED ON REQUEST ONLY

<p><b>BLIND UPPER LOOPER</b> 270-D-074/1 FOR USE WITH</p>  <p>228-00-01 228-00-05</p>	<p><b>UPPER LOOPER WITH EYE</b> 27.277-0745 27.277-074 FOR USE WITH</p>  <p>228-00-01 228-28-02</p> <p>228-00-04 228-01-02 228-10-01 228-00-05</p>	<p><b>FIXED GUIDE FOR NON-CUTTING</b> 270-401 FOR USE WITH</p>  <p>228-00-05</p>																																																																																							
<p><b>LOWER LOOPER</b> 270-075 270-075/2 FOR USE WITH</p>  <p>228-00-01 228-28-01 228-28-02</p> <p>228-00-04 228-00-05 228-01-02 228-10-01</p>	<p><b>SUBSIDIARY FEED DOG</b> 2800-B7-0511 282-B-0511 285-0511 280-0511 FOR USE WITH</p>  <p>228-00-04 228-01-02</p> <p>228-00-02</p> <p>228-10-01</p> <p>228-00-01</p>																																																																																								
<p><b>MAIN FEED DOG</b> 272-B-0501 FOR USE WITH</p>  <p>228-00-02</p>	<p><b>PRESSERFOOT PRESSURE SPRING</b> 272-092 FOR USE WITH</p>  <p>228-00-08 228-00-02</p>	<p><b>KNIFE SHARPENING BLOCK</b> 272-BK-675 270-675/1 FOR USE WITH</p>  <p>228-00-03</p> <p>228-00-01</p>																																																																																							
	<table border="1"> <tr> <td>1</td> <td>G.2721-C-181</td> <td>presserfoot complete</td> <td>1</td> </tr> <tr> <td>2</td> <td>270-183</td> <td>block</td> <td>1</td> </tr> <tr> <td>3</td> <td>2721-C-191</td> <td>tongue</td> <td>1</td> </tr> <tr> <td>4</td> <td>270-989</td> <td>screw block fixing</td> <td>1</td> </tr> <tr> <td>5</td> <td>2700-1834</td> <td>plate</td> <td>1</td> </tr> <tr> <td>6</td> <td>004-L-8</td> <td>screw plate fixing</td> <td>1</td> </tr> <tr> <td>7</td> <td>270-196</td> <td>locator</td> <td>1</td> </tr> <tr> <td>8</td> <td>2721-C-184</td> <td>shoe</td> <td>1</td> </tr> </table> <table border="1"> <tr> <td>1</td> <td>G.2721-C-181/1</td> <td>presserfoot complete</td> <td>1</td> </tr> <tr> <td>2</td> <td>270-183</td> <td>block</td> <td>1</td> </tr> <tr> <td>3</td> <td>2721-C-191/1</td> <td>tongue</td> <td>1</td> </tr> <tr> <td>4</td> <td>270-989</td> <td>screw block fixing</td> <td>1</td> </tr> <tr> <td>5</td> <td>2721-C-183/1</td> <td>plate</td> <td>1</td> </tr> <tr> <td>6</td> <td>004-L-8</td> <td>screw plate fixing</td> <td>1</td> </tr> <tr> <td>7</td> <td>270-196</td> <td>locator</td> <td>1</td> </tr> <tr> <td>8</td> <td>2721-C-184/1</td> <td>shoe</td> <td>1</td> </tr> </table>		1	G.2721-C-181	presserfoot complete	1	2	270-183	block	1	3	2721-C-191	tongue	1	4	270-989	screw block fixing	1	5	2700-1834	plate	1	6	004-L-8	screw plate fixing	1	7	270-196	locator	1	8	2721-C-184	shoe	1	1	G.2721-C-181/1	presserfoot complete	1	2	270-183	block	1	3	2721-C-191/1	tongue	1	4	270-989	screw block fixing	1	5	2721-C-183/1	plate	1	6	004-L-8	screw plate fixing	1	7	270-196	locator	1	8	2721-C-184/1	shoe	1	<p>FOR USE WITH</p> <p>228-00-06</p> <p>FOR USE WITH</p> <p>228-00-06</p>																						
1	G.2721-C-181	presserfoot complete	1																																																																																						
2	270-183	block	1																																																																																						
3	2721-C-191	tongue	1																																																																																						
4	270-989	screw block fixing	1																																																																																						
5	2700-1834	plate	1																																																																																						
6	004-L-8	screw plate fixing	1																																																																																						
7	270-196	locator	1																																																																																						
8	2721-C-184	shoe	1																																																																																						
1	G.2721-C-181/1	presserfoot complete	1																																																																																						
2	270-183	block	1																																																																																						
3	2721-C-191/1	tongue	1																																																																																						
4	270-989	screw block fixing	1																																																																																						
5	2721-C-183/1	plate	1																																																																																						
6	004-L-8	screw plate fixing	1																																																																																						
7	270-196	locator	1																																																																																						
8	2721-C-184/1	shoe	1																																																																																						
<p><b>NEEDLE PLATE</b> 270-1142 270-1143 270-114 272-B-114 275-1141 FOR USE WITH</p>  <p>228-00-01</p> <p>228-00-01</p> <p>228-00-01</p> <p>228-00-02</p> <p>228-10-01</p>		<p>272-BK-114/1 272-BK-1141 27.21-1143 27.77-1142 PM.2721-C-114 FOR USE WITH</p> <p>228-00-03</p> <p>228-00-03</p> <p>228-00-08</p> <p>228-00-04</p> <p>228-00-06</p>																																																																																							
 <table border="1"> <tr> <td>1</td> <td>G.270-1812</td> <td>presserfoot complete</td> <td>1</td> </tr> <tr> <td>2</td> <td>270-191</td> <td>tongue</td> <td>1</td> </tr> <tr> <td>3</td> <td>270-183</td> <td>block</td> <td>1</td> </tr> <tr> <td>4</td> <td>270-989</td> <td>screw block fixing</td> <td>1</td> </tr> <tr> <td>5</td> <td>004-L-7</td> <td>screw tongue fixing</td> <td>1</td> </tr> <tr> <td>6</td> <td>270-196</td> <td>locator</td> <td>1</td> </tr> <tr> <td>7</td> <td>270-184</td> <td>shoe</td> <td>1</td> </tr> <tr> <td>8</td> <td>PM.270-1882</td> <td>device thread cutting</td> <td>1</td> </tr> </table> <p>FOR USE WITH</p> <p>228-00-01</p>		1	G.270-1812	presserfoot complete	1	2	270-191	tongue	1	3	270-183	block	1	4	270-989	screw block fixing	1	5	004-L-7	screw tongue fixing	1	6	270-196	locator	1	7	270-184	shoe	1	8	PM.270-1882	device thread cutting	1	<p><b>GUIDE FOR NON-CUTTING</b></p>  <table border="1"> <tr> <td>1</td> <td>G.274-401</td> <td>guide complete</td> <td>1</td> </tr> <tr> <td>2</td> <td>PM.274-417</td> <td>bracket</td> <td>1</td> </tr> <tr> <td>3</td> <td>PM.274-402</td> <td>guide</td> <td>1</td> </tr> <tr> <td>4</td> <td>003-A-4,5</td> <td>screw</td> <td>1</td> </tr> <tr> <td>5</td> <td>001-D-7</td> <td>screw</td> <td>1</td> </tr> </table> <p>FOR USE WITH</p> <p>228-00-01 - 228-00-05</p>		1	G.274-401	guide complete	1	2	PM.274-417	bracket	1	3	PM.274-402	guide	1	4	003-A-4,5	screw	1	5	001-D-7	screw	1	<p><b>THREAD CUTTING DEVICE</b></p>  <table border="1"> <tr> <td>1</td> <td>PM.270-1882</td> <td>device complete</td> <td>1</td> </tr> <tr> <td>2</td> <td>270-1872</td> <td>blade</td> <td>1</td> </tr> <tr> <td>3</td> <td>270-1882</td> <td>blade</td> <td>1</td> </tr> <tr> <td>4</td> <td>028-A-3,5</td> <td>screw</td> <td>1</td> </tr> </table> <p>FOR USE WITH 228-00-01 228-00-05</p> <table border="1"> <tr> <td>1</td> <td>PM.275-1882</td> <td>device complete</td> <td>1</td> </tr> <tr> <td>2</td> <td>275-1872</td> <td>blade</td> <td>1</td> </tr> <tr> <td>3</td> <td>270-1882</td> <td>blade</td> <td>1</td> </tr> <tr> <td>4</td> <td>028-A-3,5</td> <td>screw</td> <td>1</td> </tr> </table> <p>FOR USE WITH 228-10-01</p>		1	PM.270-1882	device complete	1	2	270-1872	blade	1	3	270-1882	blade	1	4	028-A-3,5	screw	1	1	PM.275-1882	device complete	1	2	275-1872	blade	1	3	270-1882	blade	1	4	028-A-3,5	screw	1
1	G.270-1812	presserfoot complete	1																																																																																						
2	270-191	tongue	1																																																																																						
3	270-183	block	1																																																																																						
4	270-989	screw block fixing	1																																																																																						
5	004-L-7	screw tongue fixing	1																																																																																						
6	270-196	locator	1																																																																																						
7	270-184	shoe	1																																																																																						
8	PM.270-1882	device thread cutting	1																																																																																						
1	G.274-401	guide complete	1																																																																																						
2	PM.274-417	bracket	1																																																																																						
3	PM.274-402	guide	1																																																																																						
4	003-A-4,5	screw	1																																																																																						
5	001-D-7	screw	1																																																																																						
1	PM.270-1882	device complete	1																																																																																						
2	270-1872	blade	1																																																																																						
3	270-1882	blade	1																																																																																						
4	028-A-3,5	screw	1																																																																																						
1	PM.275-1882	device complete	1																																																																																						
2	275-1872	blade	1																																																																																						
3	270-1882	blade	1																																																																																						
4	028-A-3,5	screw	1																																																																																						

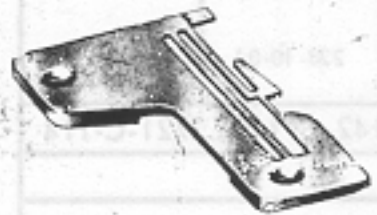
From the library of: Diamond Needle Corp

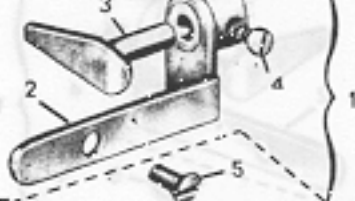
PARTS SUPPLIED ON REQUEST ONLY

<p><b>BLIND UPPER LOOPER</b> <b>270-D-074/1</b> FOR USE WITH</p>  <p>228-00-01 228-00-05</p>	<p><b>UPPER LOOPER WITH EYE</b> <b>27.277-0745</b> <b>27.277-074</b> FOR USE WITH</p>  <p>228-00-01 228-28-02</p> <p>228-00-04 228-01-02 228-10-01 228-00-05</p>	<p><b>FIXED GUIDE FOR NON-CUTTING</b> <b>270-401</b> FOR USE WITH</p>  <p>228-00-05</p>			
<p><b>LOWER LOOPER</b> <b>270-075</b> <b>270-075/2</b> FOR USE WITH</p>  <p>228-00-01 228-28-01 228-28-02</p> <p>228-00-04 228-00-05 228-01-02 228-10-01</p>	<p><b>SUBSIDIARY FEED DOG</b> <b>2800-B7-0511</b> <b>282-B-0511</b> <b>285-0511</b> <b>280-0511</b> FOR USE WITH</p>  <p>228-00-04 228-01-02</p> <p>228-00-02</p> <p>228-10-01</p> <p>228-00-01</p>				
<p><b>MAIN FEED DOG</b> <b>272-B-0501</b> FOR USE WITH</p>  <p>228-00-02</p>	<p><b>PRESSERFOOT PRESSURE SPRING</b> <b>272-092</b> FOR USE WITH</p>  <p>228-00-08 228-00-02</p>	<p><b>KNIFE SHARPENING BLOCK</b> <b>272-BK-675</b> <b>270-675/1</b> FOR USE WITH</p>  <p>228-00-03</p> <p>228-00-01</p>			
		<p>1 G.2721-C-181 2 270-183 3 2721-C-191 4 270-989 5 2700-1834 6 004-L-8 7 270-196 8 2721-C-184</p>	<p>presserfoot complete block tongue screw block fixing plate screw plate fixing locator shoe</p>	<p>FOR USE WITH</p> <p>228-00-06</p>	
<p>1 G.2721-C-181/1 2 270-183 3 2721-C-191/1 4 270-989 5 2721-C-183/1 6 004-L-8 7 270-196 8 2721-C-184/1</p>		<p>presserfoot complete block tongue screw block fixing plate screw plate fixing locator shoe</p>		<p>FOR USE WITH</p> <p>228-00-06</p>	
<p><b>NEEDLE PLATE</b></p> 	<p><b>270-1142</b></p> <p>228-00-01</p>	<p><b>270-1143</b></p> <p>228-00-01</p>	<p><b>270-114</b></p> <p>228-00-01</p>	<p><b>272-B-114</b></p> <p>228-00-02</p>	<p><b>275-1141</b></p> <p>228-10-01</p>
<p>FOR USE WITH</p>					
<p><b>272-BK-114/1</b></p> <p>228-00-03</p>		<p><b>272-BK-1141</b></p> <p>228-00-03</p>	<p><b>27.21-1143</b></p> <p>228-00-08</p>	<p><b>27.77-1142</b></p> <p>228-00-04</p>	<p><b>PM.2721-C-114</b></p> <p>228-00-06</p>
<p>FOR USE WITH</p>					
		<p><b>GUIDE FOR NON-CUTTING</b></p> 	<p><b>THREAD CUTTING DEVICE</b></p> 		
<p>1 G.270-1812 2 270-191 3 270-183 4 270-989 5 004-L-7 6 270-196 7 270-184 8 PM.270-1882</p>	<p>1 G.274-401 2 PM.274-417 3 PM.274-402 4 003-A-4,5 5 001-D-7</p>	<p>1 PM.270-1882 2 270-1872 3 270-1882 4 028-A-3,5</p>	<p>presserfoot complete tongue block screw block fixing screw tongue fixing locator shoe device thread cutting</p>	<p>guide complete bracket guide screw screw</p>	<p>device complete blade blade screw</p>
<p>FOR USE WITH</p> <p>228-00-01</p>		<p>FOR USE WITH</p> <p>228-00-01 228-00-05</p>		<p>FOR USE WITH 228-00-01 228-00-05</p> <p>1 PM.275-1882 2 275-1872 3 270-1882 4 028-A-3,5</p> <p>device complete blade blade screw</p>	
<p>FOR USE WITH 228-10-01</p>					

From the library of: Diamond Needle Corp

PARTS SUPPLIED ON REQUEST ONLY

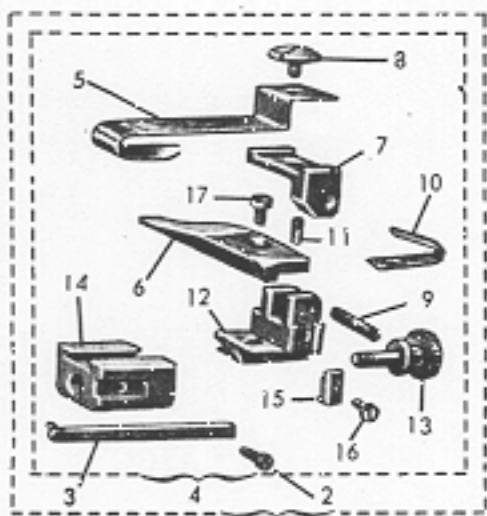
	1 AS. 275-B-413/1	guide hemming	FOR USE WITH
	2 001-D-6	screw	
	3 PM. 275-B-417	support	228-10-02
	4 G. 275-B-413/1	guide	
	5 275-B-407/B	plate hemming	
	6 275-B-411/1	guide	
	7 275-B-409	block	
	8 275-404	screw	
	9 275-B-410	pin threaded	
	10 275-B-430	spring leaf	
	11 275-B-403	screw stop	
	12 275-B-406	shoe	
	13 275-B-425	screw adjustment	
	14 275-B-408	body guide	
	15 275-B-418	locator	
	16 005-D-5	screw	
	17 004-R-5	screw	

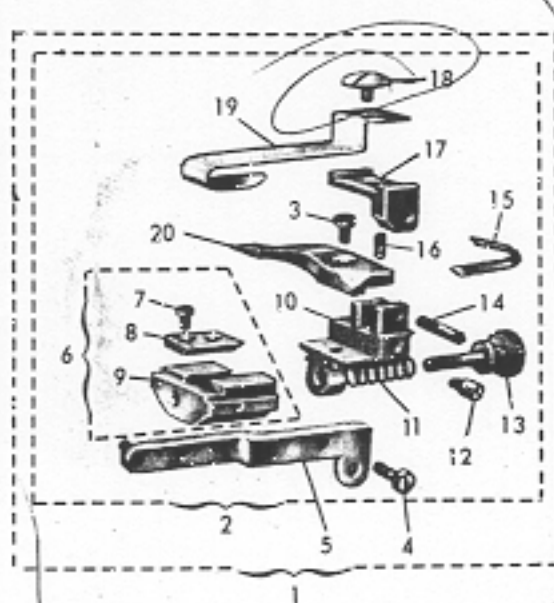
	1 AS. 275-BS-4132/1	guide hemming	FOR USE WITH
	2 G. 275-BS-4132/1	guide	
	3 004-R-5	screw	Shoulder Screw 275-B-425  228-10-03  Spring 202875-010  screw little 204973 000
	4 001-D-6	screw	
	5 PM. 275-BS-4172	support	
	6 PM. 275-BS-4082	body guide	
	7 004-A-3,2	screw	
	8 275-BS-4142	guide	
	9 275-BS-4082	body	
	10 275-BS-4062	shoe	
	11 275-BS-4152	spring	
	12 275-BS-6412	pin threaded	
	13 275-BS-4252	screw adjustment	
	14 275-B-410	pin threaded	
	15 275-B-430	spring leaf	
	16 275-B-403	screw stop	
	17 275-B-409	block	
	18 275-404	screw	
	19 275-B-407/B	plate hemming	
	20 275-B-411/1	guide	

CHAIN CUTTER	270-188
	FOR USE WITH
	228-00-01

UPPER KNIFE	270-113/2
	FOR USE WITH
	228-00-01
	207-000-200

LOWER KNIFE	270-112/2
	FOR USE WITH
	228-00-01
	2850-113

270-112 carbide  
 207-018-200 NY top

CLASS	HEAD	TECHNICAL CHARACTERISTICS				
		No. of threads	No. of stitches	No. of stitches	No. of stitches	No. of stitches
HEADING	258-10-01	100	100	100	100	100
	258-10-02	100	100	100	100	100
	258-10-03	100	100	100	100	100
	258-10-04	100	100	100	100	100
	258-10-05	100	100	100	100	100
	258-10-06	100	100	100	100	100
OVEREDGING	258-28-01	100	100	100	100	100
	258-28-02	100	100	100	100	100
	258-28-03	100	100	100	100	100
	258-28-04	100	100	100	100	100

From the library of: Diamond Needle Corp



# **INSTRUCTIONS : FOR**

- INSTALLATION AND TIMING**
- USE**
- MAINTENANCE**

From the library of: Diamond Needle Corp